

f
o
r
k
r
o
v
i
c



The Underhill Court

Alexander Bennett

DOG SOUL
publishing

d20
system

The Underhill Court

Written by Alexander Bennett

Original art by Cris Griffin and Jimmy (Dreadjim) Ling

Graphic Design and Cartography by Deborah Balsam

Edited by Tony Law

Proofed by Lisa Hartjes

Introduction	1
Overview	3
Inhabitants of the Underhill Court	4
Inside the Underhill Court	9
Ecology of the Court	13
Items of the Tuatha de Danann	14
The Pit Monsters	17
Beyond the Court	18
Maps	20
Stats	23
Sample Dialogue	29
Plot Hooks	30
Pronunciation Guide	31
Naming Conventions of the Sidhe	31

Introduction

"Tell it again, uncle!" I begged.

"Please, just once more. It's such a good story, and you add in new details every time."

He puffed on his pipe, drew in the dark smoke, and let it fill his lungs. The cabin was small, but I wondered if my uncle had heard me. With him, there would often be long stretches of contemplative silence in which his gaze would stray to the flickering log fire and, sometimes, he would give me no reply at all.

This had been his way since I was small enough to bounce upon his knee. Now I was a lad of thirteen, almost of age, but still I came to hear his stories, for there was wisdom in them.

He turned to me and sighed, his eyes ragged in the firelight, and I knew he'd been considering his answer. "It's not a bedtime story, young'n," he said. "It's more a tale of warning. But I'll tell it to you again, and perhaps this time you'll understand."

"It was many long summers ago, and my grandfather was but a boy at the time – around your age, in fact. He'd spend his days doing all the things that feckless young boys did back then, and still do now, if you're anything to go by. Bothering shopkeepers, playing hunter or soldier, tormenting his siblings; if there was mischief to be found, my grandfather found it.

One cool night, when the moon was full, he took a walk in the woods. The forest was calm, and the night air nourishing. He walked for hours, eventually wandering far away from the known paths. It was then that he came across the hill.

There it sat, dominating a broad clearing in the woods, tree-less, grassy and green. From within the hill my grandfather saw a strange light glowing, and from far beneath it he heard strange sounds of merry laughter and dancing music. This was all very strange, but fear is no match for childish curiosity, as you should well know. Carefully, he approached the hill.

He didn't see the door until he was almost upon it. It was covered in dirt and grass and set into the side of a hill but, nevertheless, the great brass handles indicated that it was a door of some importance. My grandfather did what any young boy would do; he knocked.

The door was opened for him by a pair of otherworldly creatures, the likes of which my grandfather could scarcely have imagined in his dreams. They looked like men at first, until you noted that they were taller, paler and of nobler stature than any man who ever lived. Their long hair flowed like silk to drape across their silver armor. Their eyes were cat-like, their voices deep and regal. "Enter, little one," they said. "You are expected in the great chamber below."

My grandfather followed them down into the depths of the hill. The sounds of music and merry-making grew louder and louder until, without warning, the tunnel opened out onto a magnificent ballroom. The room was opulent, fantastic, the kind of royal palace-chamber a young child might read about in his storybooks. Dozens of tall masked figures drank, danced and sang, while spectral servants hurried around them. The whole scene was presided over by a dark and brooding king and queen, enthroned on twin seats formed from what appeared to be human skulls. A grotesque little jester gamboled beside them.

What happened next chilled my grandfather to the bone. The music ceased, the dancers stopped dancing, and a hundred cat-like eyes turned to look at him. They regarded him without malice, but rather with the feral curiosity of the predator viewing its prey. The enthroned queen stood up, and my grandfather saw that she was both extremely tall and heart-breakingly beautiful. "Mortal child, you are just in time," she said, with a voice like the north wind. "The sidhe grow bored. You will provide us with an entertaining diversion."

The dark queen turned towards the back of the ballroom, and the eyes of the masked dancers followed her gaze. Set into the floor of the great chamber was a ringed pit, such as those used by ancient races to stage gladiator battles. The dirt in this pit was stained the color of rust, and white sticks



– perhaps they were bones – were strewn around it.

My grandfather thought quickly, for somehow he knew his young life depended on the next words out of his mouth. He thought of the queen's speech; she had called these creatures sidhe. He had heard that word once before, in the teachings of the village wise woman. Desperately, he tried to recall the stories the old woman had told.

"Noble sidhe," my grandfather began, and swallowed hard to stop his voice from trembling. "Are you not the descendants of the Tuatha de Danann, the first and rightful inhabitants of this land, mighty enemies of the giant Fomori? On the surface world, my people tell stories about your greet deeds. I am honored to meet you." In case this wasn't enough, he then dropped to one knee and bowed his head.

There was a great silence in the ballroom. Then the king rose from his throne, and my grandfather saw that this king had antlers like a stag.

"This young one is a historian," the king said. "No harm may come to him. He is our guest tonight."

There was cheering at this proclamation, and the masked dancers resumed their revelry in earnest. The queen, however, wore an expression of icy rage. My grandfather suspected she'd have preferred him thrown in the pit.

All that night, my grandfather danced among the sidhe. He ate of their food, drank of their wine and listened to stories as old as mankind. It was the most exquisite night of his life. The next night, he returned to the hill in the forest. Then the night after that, and so on until they blurred into a wondrous waking dream.

He tried to bring other children there from the village, but not one of them believed him and none would go. Once, he sought the hill during the day. It was there, but there were no sounds coming from below, and try as he might he could not find the great door with its brass handles. But it was there that night, and every night for a whole month my grandfather returned to the place under the hill.

Then, one night, it was gone.

Without warning, the landscape changed. There was no clearing and no hill, and as far as my grand-



father could tell, there never had been. He traced and retraced his steps, but the sidhe were gone.

The Court had moved on.

My grandfather spent most of his life looking for that hill. He searched across the world for it, but in vain. Eventually, he did the sensible thing and settled down to start a family. He married a nice girl, and all was right for awhile. But my mother's mother was not a happy woman, for her husband did not truly love her. She used to say he was in love with his childhood, his dream of an underground palace where the ancients danced all night.

One day, my grandfather saw that he had grown old and frail. He had become a burden to his family, and he was not long for this world. So he said his goodbyes to us, and he walked away into the woods. We never saw him again. And yet, the village hunters who were in the forest that night heard strange sounds, like the far-off echo of music and laughter.

And that, young'n, is the end of the story. Now, it's off to bed with you!"

"But uncle, you never tell me any of the good parts of the story," I said. "Who were the Tuatha de Danann? Why was the beautiful queen so cruel? Did your grandfather ever find the hill again, in the end? Did they—"

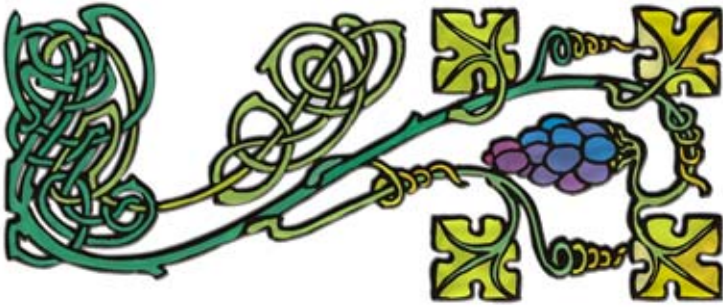

“That’s enough, lad. A story is spoiled when you ask too many questions about it. And a wise man doesn’t ask questions about the sidhe.”

“But I don’t want to be a wise man, uncle. I want to be an adventurer.”

My uncle laughed long and hard at this, and then he sent me off to bed. I should be there now, wrapped in warm blankets, but I cannot sleep. I hang my head out the window and look at the forest. I breathe in the night air and I imagine I can hear music in the distance.

I may be young, but I know one thing with certainty. Somewhere out there in the darkness of the forest, there is a hill. And I’m going to find it.

Overview

There is a place in the woods, a magical realm where human laws do not apply. In this timeless place, the last remnants of an ancient race hold court. This is a place of mystery, danger and dream. Welcome to the Underhill Court.

The Underhill Court is a mini-setting that GMs can drop into their campaign. It is essentially a fairy court that moves from place to place, and so could appear just about anywhere in a world with

an appropriate stretch of forest. The inspiration for the Underhill Court comes from Irish-Celtic myth and folklore.

This chapter contains vital information for the GM. It sets out the facts about the Underhill Court in a manner that is easy to understand and use in a game. However, keep in mind that the Underhill Court should not be used as a typical, every-day location. It is an extremely magical and confusing place, wherein the usual laws of space and time do not apply. The GM may wish to emulate traditional fairy tales by making the Underhill Court a place of mystery; time passes differently there, and PCs may feel as if they are part of a dreamscape.

The origins of the Underhill Court are shrouded in the mists of time, but a few learned human sages may still know the basic details of the legend. Thousands of years ago, a great race of beings called the Tuatha de Danann – the ‘Children

of Danu’ – ruled the known world. They were warriors, artists, and wanderers, and their very souls were infused with magic. They fought mighty battles against tribes of giants known as the Fir Bolg and Fomorians but were finally defeated by the Milesians, a treacherous race from across the sea. The Tuatha de Danann were crushed, and as penance they were forced to live underground, driven into hiding from their enemies. In addition, the Milesians stole the secrets of a magical ritual which the Tuatha de Danann used to reproduce; since that time, no new Tuatha de Danann have been born into the world.

Over the long centuries, the underground hill tribes of the Tuatha de Danann slowly disappeared. Their noble blood became diluted, and they lost many of their magical gifts. They were hunted and hounded by remnants of the other ancient races. Finally, they gave up their old title and took to calling themselves by the name humans gave them: ‘sidhe’, from the human word for a fairy hill.

Today, only one of these sidhe strongholds remains. It is a great underground sidhe palace, the royal court of the last sidhe king and queen. Twice a year, on the eves of Brightfire (the first day of summer) and Longshadows (the first day of winter), the Court disappears and appears in another place. This new location is often hundreds of miles away. No matter where it travels, the Court always resides beneath a green, grassy hill, usually in the centre of a dark forest.



Inhabitants of the Underhill Court

The Court itself can only be entered at night; during the day, all entrances disappear completely. Anyone still inside the Underhill Court when dawn breaks finds themselves suddenly lying on top of the green hill.

Wherever the hill appears, strange things are bound to occur. Nearby human settlements are always affected. Woodsmen mysteriously disappear while following dancing lights, strange woodland beasts awaken, and giants stalk the land. Most dangerous of all, the Wild Hunt is often seen roaming the forest in search of prey.

It is the last bastion of sidhe power in the world. It is known by many names – in fact, it has thousands – but most humans simply call it the Underhill Court.

Lord Auberon

The last noble king of the Tuatha de Danann, Auberon is something of a tragic figure. He sits on a throne of skulls beside his queen, Lady Titania, in the great ballroom that is the centre of the Underhill Court. Every night, he and Titania watch over the wild festivities, lively dancing, and courtly intrigue that take place in the last sidhe court. Some nights they will sit silent as statues, merely observing. On other nights they may partake of food, converse with some of the nobles of high standing, or even be entertained by the antics of the court jester. Yet, even on these occasions, the king and queen seem distant and unfath-

omable. For some reason, they never seem to converse with each other.

Like all sidhe, Auberon is tall and muscular with pale, almost translucent skin. His eyes are slitted like a cat's, and stag-like antlers jut from his head. Combined with his deep, echoing voice, his appearance can be quite intimidating.

Lord Auberon's personality is complex, given that he is many thousands of years old. He enjoys pondering philosophical questions over timespans as long as several years, and will occasionally ask a guest's opinion on a certain piece of philosophy, folklore, or mythology. He comes across as gentle, aloof, and utterly calm. However, there is an air of melancholy around him, as if he knows his glory days are long past. Although Auberon and Titania rarely so much as acknowledge each other's presence, he seems to bow to her wishes in most matters.

Auberon's current machinations revolve around the goal of keeping his kingdom – the last sidhe court in existence – alive and whole. To this end, he tries to carefully defuse quarrels and feuds between the lesser sidhe nobles. He also nurses clandestine plots against the remaining kingdoms of the Fir Bolg, Fomorians, and Milesians. In the furthering of both these goals, Auberon greatly prefers to use pawns and proxies rather than risk sidhe lives.

Auberon's dearest wish is to some day restore the lost glory of the sidhe by regaining the magical creation ritual from the clutches of the Milesians.

Lady Titania

The queen of the Underhill Court is not a woman to be trifled with. She likes to promote the idea that she is fun-loving, magnanimous, and fair to her subjects, but if she is ever slighted, the offender can look forward to a slow, painful death in the fighting pit... or as the main course of that night's banquet.

Titania is incredibly beautiful in a predatory, feline sort of way. Her hair and eyes are as black as midnight on a moonless night, and her voice is the razor-sharp chill of the north wind. She speaks carefully, measuring every word, and woe betide the poor fool who interrupts her in the middle of a sentence.

The queen of the Underhill Court seems to take more of an interest in her subjects than Lord Auberon does. Titania occasionally embroils herself in courtly intrigue, championing this or that petty noble, then dropping them in favor of another, more interesting charge. Some nights, one or more of her subjects will present her with lavish gifts of stunning craftwork, artfully-composed musical pieces, or stirring bardic tales. If she enjoys the gift, the sidhe who gave it to her can look forward to wondrous



riches and at least a few nights in the spotlight of her patronage. But if she is somehow offended by the gift, the giver's immortal lifespan suddenly becomes much, much shorter.

The only inhabitant of the Court who seems to remain constantly in Titania's favor is the jester. His strange antics and provocative rhymes never fail to amuse the great lady.

In truth, Titania has become petty and small-minded in her old age. Her relationship with Lord Auberon soured centuries ago; in her opinion, he spends too much time worrying over military matters and not enough on her. In her eyes, he is a fool to believe in lost glories and the possibility of restoring the past. For Titania, all that matters is the here and now, and the tiny joys to be gained from the torture, humiliation, or death of those outside her favor.

The Jester

The Underhill Court's very own court jester does not appear to be a sidhe at all. His body is brown and furry, and his limbs are long like an ape's. His face, however, is constantly hidden behind a leering jester's mask. There are some among the Court who whisper that he is an enslaved Fomorian, one of the ancient enemies of the Tuatha de Danann, who successful-

ly bargained for his life when that race was destroyed. Whatever the truth, the jester refuses to discuss it. He prefers to go by no name, but if pressed for one, he tells people to call him simply 'the Puck'.

The jester enjoys nothing more than a good prank. Practical jokes are his specialty, but he also enjoys pointing out peoples faults and flaws, usually in the form of a

The jester understands the true absurdity of the Underhill Court – a race of immortal beings stuck in a permanent state of stasis, unable to evolve or procreate – and this understanding forms the basis for much of his humor. He is the only being in the Court with the ability to point out that 'the emperor has no clothes', as it were; anyone else making similar observations would most likely find themselves disemboweled.

The jester walks a fine line between the favors of his Lord and Lady. He often meditates between the two during their frequent bouts of self-imposed non-communication. He also acts as the Court messenger on the extremely rare occasions that the sidhe need to contact the world above.

The truth about the jester is far stranger than any would guess. He is, in fact, a Fomorian-sidhe crossbreed, created in a bizarre magical experiment performed centuries ago by an insane Milesian sorcerer. Auberon rescued the jester from the clutches of the Milesians, and the stunted creature successfully bargained for his life. The hybrid later proved his worth by serving his Lord as a squire during the final war between the Milesians and the Tuatha de Danann. The jester has much of the appearance of a Fomorian but lacks the strength and size of that race; he appears to have inherited the immortal lifespan of a sidhe.

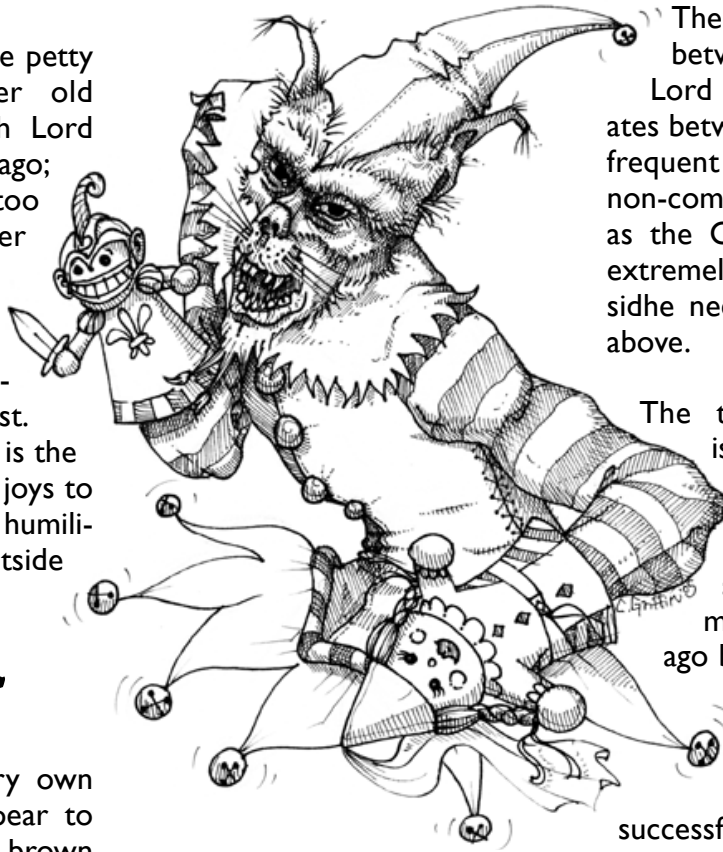

nasty rhyming song. Despite his ridiculous nature, the jester holds considerable sway in the Underhill Court. Those he singles out for ridicule become the laughing stock of the Court, and his opinions seem to be much valued by the Lady Titania.



The Nightly Guests

Every night, the sidhe inhabitants of the Underhill Court gather in the great ballroom to eat, drink, and dance the night away. Their numbers seem to fluctuate, but are usually somewhere around a hundred. Every guest is dressed in splendid evening finery which would be the envy of human royalty and their faces are covered by strange masks, each one in the likeness of a different animal. These costumes and masks seem to change with the seasons, following a somber winter theme one month before blossoming into the colors of spring.

The nightly guests are a diverse lot. On the rare occasions that humans visit the Court, the guests are likely to take them under their wings, involving and using them in their constant games of intrigue. They are always interested in stories of the world above, but humans may find that their knowledge of surface kingdoms and current events is centuries out of date. Due to the sidhe gift for speech, most of them will be fluent in many surface languages. Their turns of phrase may be extremely outdated, however, even to the point of being incomprehensible.

Some of the sidhe guests scheme and plot to win the favor of Lady Titania, or to have their opponents chastised by the court jester.

Others are just there to have a good time. All of them, however, enjoy the great spectacle that is had whenever someone is thrown into the fighting pit to battle for their life against savage creatures.

Most of the sidhe guests can be divided into two philosophical camps: the aesthetes and the intellectuals. The aesthetes are the artists, musicians, poets, and hedonists who constantly jostle for Lady Titania's favor. They plan to spend all eternity partying like there's no tomorrow. The intellectuals are less content with their lot; they are the strategists, historians, storytellers, and sorcerers who still allow themselves to remember the good old days of the Tuatha de Danann. These sidhe support Lord Auberon's dreams of a better future, and they are often the ones most interested in visitors from the outside world.

The aesthetes and intellectuals may be identified by their choice of mask. Aesthetes favor mamma-

lian likenesses (cats, dogs, badgers, apes, etc), while intellectuals wear masks in the image of various birds (ravens, eagles, and owls are the most popular).

The Sidhe Warriors

These ancient guardians protect the Underhill Court from enemies and intruders. The last proud descendants of a great warrior tribe, they stand guard at the entrance to the hill and at the doors leading out of the great ballroom. They wear silver armor and carry slender silver swords that never seem to bend or break, indicating that the sidhe possess knowledge of magical weapon-working, or did in the past.

Human sages have speculated that the sidhe warriors are a lesser class of sidhe, and the dancing guests are the upper-class nobles of their race. However, because the guests' masks make identifying them impossible, the sidhe warriors might simply be some of the masked guests acting as guards on some kind of rotating roster.

The sidhe warriors take their duty very seriously and will rarely chat with interested visitors. They protect the main hill entrance from any who approach it unless they have a good reason for entering the Underhill Court. The warriors also maintain the fighting pit, feed-



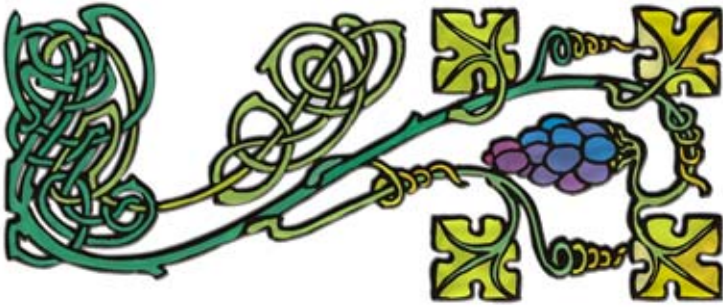

ing and looking after the various beasts that live in the silver cages below it: dire wolves, lions and, occasionally, even the odd manticores.

The Sluagh Servants

These ghostly apparitions are servants to the sidhe, cooking their food, serving the masked guests and tending to the nightly running of the Underhill Court. The sluagh look something like ethereal, elongated sidhe, but their faces are blurred and distorted to the point where it is impossible to tell one sluagh from another.

Some speculate that the sluagh are the ancestor-ghosts of the sidhe, serving their brethren in the afterlife. Others postulate that they are the shades of people defeated by the Tuatha de Danann in ancient times. Whatever the truth, the sluagh do not seem capable of speech and the sidhe will not talk about them, barely even acknowledging their presence.

If any humans were to go beyond the great ballroom into the deepest parts of the Underhill Court – a rare occurrence, as sidhe warriors vigilantly guard the exits of the ballroom – they would discover an ever-changing maze of vaults and chambers tended to by the sluagh. There is a garden of exotic plants growing miraculously

underground, kept healthy by their sluagh

gardeners, a vast music room where the sluagh carefully polish ancient instruments, and even a library filled with ancient sidhe knowledge, kept dust-free by dutiful sluagh.

The truth is that the sluagh are, in fact, the ghosts of an entire city of Milesians. Ages ago, the city surrendered to an army of the Tuatha de Danann and its entire population was ritually slain during the casting of a massively-powerful spell. This is one of the reasons for which the surviving Milesians still hound the Underhill Court; they wish to release their ancestors from eternal servitude.

The Underhill Court has many enemies. Wherever it goes, the eerie magical events that accompany it can stir up angry mobs of irate, pitchfork-wielding humans. Luckily, the forest beings known as woodwose have appointed themselves as protectors of the hill that contains the great sidhe Court.



The Woodwose

These woodwose look like grinning, green-skinned men, their bodies wrapped in vines, their faces surrounded by a beard of green leaves. They dwell within the forest around the Underhill Court, watching the paths used by humans, turning them away if they get too close to the Court. They have the ability to step inside any large tree, hiding within its bark until such time as a human interloper walks by, at which point they leap out, claws first. They lack speech, but seem to be able to distinguish between those who wish harm to the Underhill Court and those who seek it for peaceful reasons. They do, however, make mistakes, and a party of armed humans who fail to show proper respect to the forest will usually be targeted for attack.

The woodwose seem to spontaneously appear in a forest at the same time as the Underhill Court. Whether they are forest spirits awakened by the Court's presence, or whether they are servants of the Court who move with it, no mortal can say. In reality, the woodwose are the product of an enchantment jointly cast by Auberon and Titania back in the days when they were on speaking terms with each other. The enchantment is an ancient Tuatha de Danann rite for communing with nature by summoning forth the 'souls' of nearby trees. Now, the Underhill Court's mere pres-



ence is all that is required to bring forth these arboreal souls and give them solid form. If slain, their bodies grow incorporeal and disappear in a matter of minutes.

Herne the Hunter

There is a dark and terrible aspect to the Underhill Court, one that calls to mind the ancient warrior ways of the Tuatha de Danann. Its name is Herne the Hunter, and whenever the Court appears in a forest, he follows not long after. Herne the Hunter is the leader of the terrifying Wild Hunt, a timeless ritual that stands for the primal power of the forest. Very few humans have seen the Wild Hunt and lived to tell about it, but those that have describe it the same way: a pack of snarling hunting dogs, their eyes blazing with red light, led by a shadowy figure on horseback. This figure is huge and muscular, with a great bloody spear in hand and antlers protruding from his head. He blows upon a great horn that sounds a deep note of death and pain, frightening to mortal ears. He and his entourage hunt only in the forest around the Underhill Court. No human has ever seen his face.

Even the sidhe do not know exactly who, or what, Herne the Hunter is, and the Wild Hunt is a source of much speculation at Court. There is one clue: both Herne and Lord Auberon are antlered. Yet it is difficult for anyone to imagine the

calm, collected king of the sidhe leading a feral hunting pack. And besides, Auberon can be seen sitting on his throne every night, while Herne hunts in the forest above. A man can hardly be in two places at once... can he?

The truth of this mystery has its roots in a terrible pact, signed and sealed in blood. Centuries ago, the hill courts of the sidhe were under siege from the remaining armies of Milesians, Fir Bolg, and Fomorians. One by one they fell, and there was no longer any way to bring new sidhe into the world.

The race seemed doomed. But Lord Auberon, ruler of the last known sidhe court in existence, was determined to save his people. He conjured forth a primordial deity known as Nuadhu, 'the silver hand', and begged for its help. The deity offered him a bargain: Lord Auberon's court would be given

the means to escape its enemies by shifting its location twice a year to a far away land. In return, Auberon's soul was to be split in two, creating a dark shadow half that would forever haunt him. Auberon agreed, and Herne was born.

Herne is the darkest, cruelest side of Auberon's personality, the part of him that revels in rage and bloodshed. Herne seeks to slay his maker, but Auberon has crafted warding spells to ensure that Herne may never enter the Court itself. Interestingly, now that he lacks his shadow self, Lord Auberon's military mind has grown weaker. He is no longer as ruthless or willing to take risks as he once was. If Herne were ever destroyed, the pact would presumably be broken, and the Underhill Court would no longer be able to teleport on the eves of Brightfire and Longshadows.



Inside the Underhill Court

Each entry in this chapter consists of a short description of the location followed by descriptive text which the GM may read aloud to the players. Finally, there is a short sub-chapter concerning reactions to, and consequences of, possible PC actions.

THE HILL ENTRANCE

The great green hill which sits atop the Underhill Court is, at first glance, completely innocuous. At night, faint music can be heard as soon as anyone steps onto the hill, and a large bronze-handled door can be found on the eastern slope of the hill, underneath grass and soil. During the day, however, it is a completely normal hill; at this time, the Court exists in another dimension entirely and even digging up the hill would produce absolutely nothing out of the ordinary. In this case, the hill simply restores itself when night falls.

Read aloud: *'Stars twinkle in the night sky and the air is fresh with the scent of the forest. The clearing looks utterly still and calm, yet a strange noise disturbs the quiet; from deep within the hill itself comes the unmistakable sound of pipe music.'*

If the PCs search the hill and find the door:

'Finally, you stop your search at the point where the sound of music is loudest. You feel around in the grass and your hands touch metal. Set into the hillside are two large bronze handles, as if part of a great door.'

If the PCs knock, or open the door:

'Dirt and grass fall away as the great doorway swings out and open. Inside, you see a long tunnel leading down into the depths of the hill. Your way is blocked, however, by two tall figures in bright silver armor. They raise wicked-looking silver halberds and point them in your direction.'

THE GRAND BALLROOM

This is the heart of the Court, the area where all important activities take place. All rooms and corridors beyond the great ballroom exist only hazily, and are subject to constant change. This huge room is a combination of meal area, throne room, royal court, ballroom, and stadium.

Read aloud:

'This vast room rings with the merry sounds of laughter, music, and dancing. It is opulently decorated, adorned with great lamps, gilded mirrors, and artful tapestries. The only part of the room that seems out of place is the ceiling – it is simply clotted dirt, with tree roots hanging down. Dominating the western side of the room are two great thrones that appear to be made of piled-up human skulls. Upon them sit two marvelous figures who you take to be the king and queen. Beside them, a hairy little jester dances and plays. The regal pair are presiding over what looks like a huge party; the room is filled with perhaps a hundred figures all leaping, swaying, and dancing in time to the music of unseen fairy pipes. All of the dancers wear masks in the likeness of various woodland animals – you spot wolves, stags, eagles, rabbits, and bears, along with many more.'

THE FIGHTING PIT

Installed at the behest of Lady Titania, the fighting pit is a favorite pastime of many sidhe, especially those with a love of violence and gambling. Some seasons, when





morale in the Court is low, the Lord and Lady will declare whole nights – or even weeks – be devoted to arena fighting. If no suitable humanoids can be found for the pit, two of the many monsters from the holding pens below will be selected.

Of course, in order to acquire these monsters, the sidhe warriors who operate the fighting pit must venture to the surface world. Aside from the odd military expedition, this is virtually the only time in which any sidhe will leave the confines of the Court.

Read aloud:

'The ghastly pit smells like blood, fear and death. Grey bones, some with ragged bits of flesh still clinging, lie scattered on the coppery sand. The walls are spiked, presumably to stop anyone trying to climb out. Looking up, you see the grotesque masked faces of the sidhe dancers leering

down at you, whooping and cheering. Then a terrible noise makes your heart skip: an ominous grating sound. It is the sound of the gate at the opposite end of the pit being lifted. What manner of creature waits behind it?'

THE KITCHENS

This is where the ghostly slough servants prepare the night's meals. Most of the food is conjured using powerful ancient artifacts, but some is occasionally brought in from the surface world by the woodwose, slough, or other helpful woodland creatures. The kitchen includes a magical everburning oven and a room enchanted with perpetual cold.

Read aloud:

'A wondrous medley of aromas assaults your nostrils as you enter what is evidently the kitchen. The

room is huge, almost as big as the ballroom, and dominated by long benches upon which sit an array of ingredients. Many are exotic and strange, and some you have only heard of and never seen. At the far end of the room great ovens crackle with heat and mist rises from something that appears to be a kind of frozen pantry for cold food. Strangest of all is the activity in this room. At first glance, it seems like pots, pans, and cooking implements are flying around the room by themselves. As you focus your eyes, however, you see that they are actually being carried by tall, ghostly beings who flit hurriedly this way and that.'

THE MUSIC ROOM

This quiet room is kept scrupulously clean by the slough. In centuries long past, Lady Titania was a bard and musician of world-renowned skill. She long since gave it up, and though she hates being reminded of those happier days, she has decreed that this room remain part of the Court. The music room is filled with many instruments of improbable design. Several are quite exquisite, being made of exotic materials such as whale bone, gold, or unicorn hair.

Read aloud:

'This room is opulent and well-appointed like the ballroom, but with an air of tranquil calm. Strange musical instruments sit on pedestals, or inside glass cases, like museum exhibits. On the walls





nearby, large bookcases contain what seems to be sheet music. The instruments themselves are bizarre, recalling those used by ancient human tribes but infinitely more delicate and finely-crafted.'

THE LIBRARY

The library of the sidhe holds thousands of books of varying age. Some are written in various human scripts, but the vast majority contain the spidery hieroglyphic scrawl of sidhe lettering. The most dangerous sorcerous books – those containing rites to ancient Tuatha de Danann gods such as Danu, Nuadhu, and Ligg – are kept in a locked safe at the far end of the room. Barely-visible slough lurk in this room, ready to raise the alarm if any non-sidhe were to tamper with the safe.

Read aloud:

'This three-story room is filled with the comforting smell of old books. Volume after dusty volume is piled high, in no apparent order, on shelves that reach all the way to the roof. Toward the back of the room the books seem to get more and more ancient, until you finally come to a locked vault at the very back. The door to this little chamber is secured with a heavy golden chain.'

THE GARDEN

The garden was originally created as a place for herbalists and alchemists to cultivate components for their experiments. The plants are gathered from all the different for-

ests the Court has visited, brought down from the surface by woodwose or dryads, and kept alive through magical lighting and watering systems. Although very few surviving sidhe still practice the magical arts, some come here simply to enjoy the tranquility.

Read aloud:

'As you step into the room, you almost forget for a moment that you are underground. The air in here is wet and warm, and smells of freshly-tilled earth. The room is completely dominated by plants of all shapes and sizes, from tiny tulips to huge-leafed bromeliads and mighty oaks. The plants seem to be organized by type and they look carefully tended. Most mysterious of all, they seem to be growing without any readily-apparent source of sunlight.'

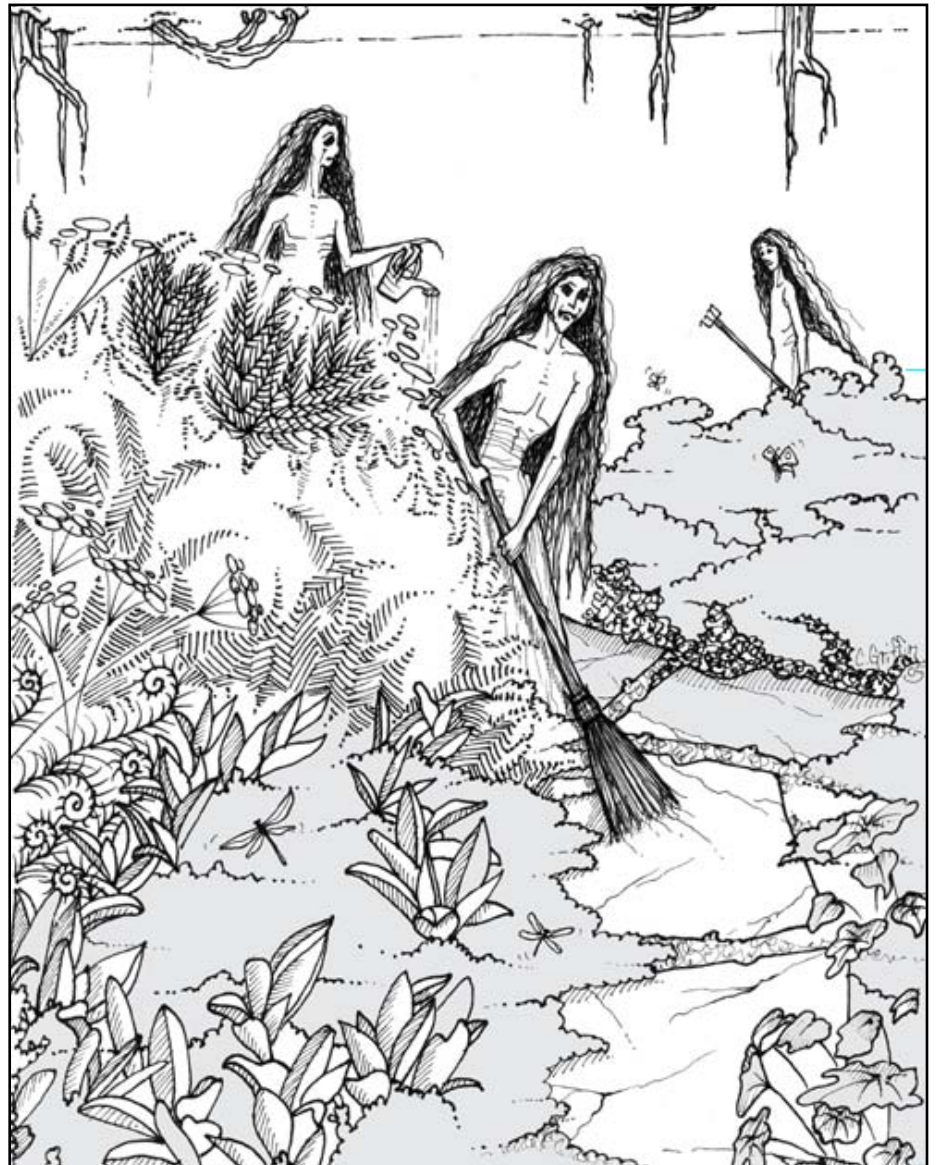



THE WILD HUNT

Herne and his Wild Hunt are a dark curse that follows the Underhill Court wherever it goes. They tend to hunt only in the forest, and usually within a few miles of the Court, but sometimes roam further afield. Mechanically speaking, the Hunt consists of Herne mounted on a nightmare, followed by 1d8+8 dire wolves. The animals are completely under Herne's control and will follow his mental commands without hesitation. If Herne is slain, they will flee.

Read aloud:

'The night's stillness is broken by a distant sound, something like a deep, low hunting horn. The sound hangs in the air for a moment and then is answered by a chilling baying. A pack of wolves, perhaps? You look around but see nothing but trees and blackness. A minute passes, then another, and then the sound returns: the same harsh horn-call, but closer this time. It must only be a few hundred yards away, yet you cannot place the exact direction. Again the horn is answered by the baying of dogs; this time you see them. They crash through the underbrush towards you, their eyes ablaze with hellish light, their jaws slavering. Behind them, a dark rider follows. The man holds a great hunting horn and a long wooden spear, entwined with vines. Dark fires burn in his eyes and upon his head are bloody antlers. Silently, he raises the spear and charges towards you!'

PLAYER ACTIONS AND CONSEQUENCES

The preceding location descriptions raise some questions about

the consequences of PC actions in these locations.

With regard to the hill entrance, players who open the door to the hill will be met with an immediate challenge from armed sidhe guards. If they are expected on official business with Auberon or Titania, they will be admitted at once. Likewise, if they have a good reason for visiting ("We bear a message of peace from a nearby human town") or they can come up with a decent ruse on the spot ("We are a band of traveling entertainers here to perform for your king and queen"). Unless the PCs are known to, and trusted by, Auberon and Titania, their weapons will be politely removed from them before they are allowed to enter the great ballroom.

If PCs cause a fuss, are caught stealing, or harm any sidhe or slugh while in the ballroom, kitchen, music room, library, or garden, their actions have immediate consequences. If, in the ballroom, they will immediately be attacked by 1d10+5 sidhe warriors; Titania will also use her spells if needed. In the kitchen or library they will immediately be attacked by 1d8+4 slugh; 1d4 rounds later, 1d6+2 sidhe warriors arrive. In any other location, 1d6+2 sidhe warriors arrive in 1d4 rounds.

Unless the PCs are especially powerful, the sidhe will attempt to knock them unconscious so as to use them in the fighting pit.

If the PCs somehow defeat the Wild Hunt and slay Herne, Auberon will immediately know of his death. The king will send out slugh and woodwoose messengers to find the PCs and bring them back to the Underhill Court. Once there, Auberon will most likely want to judge the PCs for himself. He will either consider them too dangerous and unpredictable to let live, or he will decide to use them as part of his military plans.

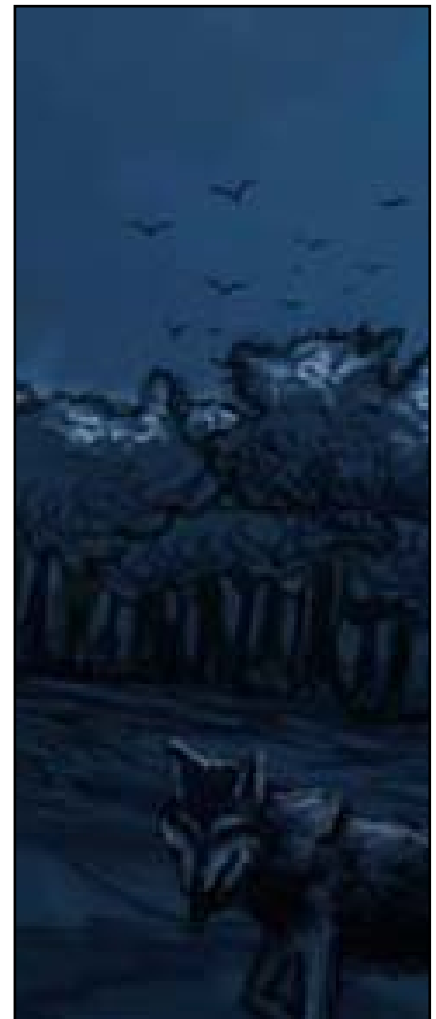

Ecology of the Court

This chapter contains details of the day-to-day running of the Underhill Court and clarifications on the magical nature of the sidhe, their home, and their belongings.

MAGICAL REALITY

They say reality is what you make of it, and the sidhe have made themselves a home unlike anything in the world of men. The Tuatha de Danann were always highly magical creatures, able to walk the pathways between dimensions with ease. Their descendants have lost much of this ability, yet the fact remains that the sidhe exist slightly outside normal reality. This is why the sidhe rarely visit the world above; they feel slightly out-of-sync with human reality, just as humans do in the Underhill Court.

For humans in the Court, time passes at about half normal speed. If a human were to, for example, spend two hours drinking and dancing in the Court, he would find that only one hour had passed in the surface world. The sidhe therefore get an entire day's worth of time out of each human night.

The sidhe, and even the Court itself, are completely nocturnal. The Court only exists for the period between sunset and sunrise; outside of this time, the hill containing the Court is a completely normal hill. At this time, the Court resides in another dimension, while the sidhe slumber in their sleeping chambers. No non-sidhe can physically, or magically, enter the Court at this time. If

they are inside the Court when the change takes place, they are instantly transported out.

The most real, stable part of the Underhill Court is the central great ballroom. Most sidhe spend virtually all their waking time here.

All other rooms and corridors exist in a state of flux. They are somewhere deeper in the earth, but their exact location – and the corridors leading to them – change constantly. A human setting foot outside the great ballroom could potentially wind up in the library, music room, garden, or kitchen, but the corridors almost never lead to the treasure room, barracks, or individual sidhe sleeping quarters. Alternatively, the human might simply wander the corridors, hopelessly lost, until the break of dawn.

The sidhe, however, can control the fluctuating magic of the corridors. A sidhe leading a group of humans could make the corridors lead to wherever he or she desired.

The following is a random table for determining which room PCs end up in when they follow a corridor. Note that a result of 'Underneath the fighting pit' causes the PCs to end up in the rooms below the pit, adjacent to the monster cages.

A result of 'GM's choice' means just that, but the GM is free to choose from any of the non-standard rooms that humans normally cannot get to. If a roll on this table indicates a room that the PCs have

just left, the corridor may lead to the PCs arriving at the door they just exited through – or even one on the opposite side of the room – causing much confusion for those accustomed to the normal laws of physics.

Random Destinations Table (d12 roll)

1-3	Ballroom
4-5	Entryway
6-7	Kitchen
8	Library
9	Music room
10	Garden
11	Underneath the fighting pit
12	GM's choice: (barracks, treasure room, or sleeping quarters)

THE SIDHE THEMSELVES

The sidhe are a proud race, but they have lost much of their ancient heritage. Their inability to reproduce more of their species, combined with their self-imposed isolation, has led to a general melancholy and a weakening of their racial memories. The sidhe are trapped in stasis, their intellects eroding from inactivity.

The sidhe who fall into the aesthete faction may boast of creating great sonnets or beautiful sculptures, but they have not been able to create anything truly original in centuries. Likewise, the intellectuals can only preserve or rediscover past achievements; they seem incapable of creating any new theories or philosophies. For this reason, the sidhe are incredibly hungry for news of the world above. Human



visitors with a gift for storytelling, history, philosophy, strategy, or music are pampered and coerced into sharing their knowledge with the sidhe.

The sidhe have an almost irrational fear of iron items and weapons. Most weapons from the surface world seem to do very little damage to them, with the exception of iron. Only the oldest and wisest sidhe remember the cause of this strange affliction: A Milesian curse, laid on the Tuatha de Danann in the time when the world was young.

ITEMS OF THE TUATHA DE DANANN

The immortal sidhe believe that money and worldly goods are fleeting. They have little regard for coin, but are endlessly fascinated by its effects on other races. If a sidhe is ever asked for payment or reward, they are honor-bound to give the asker a pouch full of gold coins. There is just one catch; when exposed to daylight in the world above the hill, all the coins immediately become leaves, twigs, and dirt.

Sometimes, as a test, the sidhe will allow the Court's ever-changing corridors to lead a human directly to the treasure room, an unguarded vault piled high with gold coins,

ingots, gems, and jewelry. If the human is

foolish enough to steal from this room, he will quickly find himself lost in a maze of corridors, then hunted down and trapped by sidhe warriors.

The sidhe do have great respect for magical items; to them, these wonders represent the lost wisdom of the old age. Many sidhe items are forged from silver using a magical alloying technique that is now forgotten. The sidhe refer to these items as 'silvrón', and they are incredibly light, flexible, and almost impossible to break. Silvrón items have a bonus of +10 to their Hardness value; in addition, silvrón

armor never reduces its wearer's speed.

The sidhe occasionally give magical items as gifts to exceptionally worthy human visitors.

Legacy Sword

This is one of the legendary swords of the Tuatha de Danann. It is impossibly old, having been forged in a time before mankind. The sword appears to be made of folded silver with gold inlay, but it is as hard as steel. The Legacy Sword counts as a longsword +2, however its real power lies in the ancient sidhe magics placed upon it. The sword allows its wielder to commune with his own ancestors, learning from their wisdom and adding their abilities to his own.

Legacy Sword abilities (d100 roll)

1-14 – Barbarian	Uncanny dodge, rage 1/day.
15-29 – Fighter	Choose one fighter bonus feat.
30-44 – Ranger	Rapid Shot or Two-Weapon Fighting.
45-59 – Monk	Evasion and flurry of blows (may use special monk weapons).
60-74 – Rogue	Evasion and sneak attack +1d6.
75-84 – Bard	Bardic knowledge (can use any character level + Int modifier) and 4x0th-level spell slots (chosen from bard spell list).
85-89 – Cleric	Turn or rebuke undead and choose one domain and gain the 1st-level domain spell for that domain.
90-94 – Druid	Wild empathy and woodland stride.
95-99 – Wizard	Two random 1st-level spells from the wizard spell list.
00 – Special	Roll twice on this table and gain both class abilities.



At the start of every day, the wielder of the *Legacy Sword* rolls on the table below to see which of his ancestor's abilities he can call on for that day. The wielder immediately gains that ability for 24 hours. If the result is a class that the wielder already has levels in, re-roll on the chart.

HANDS OF THE FOREST

These plain gloves appear to be woven together from leaves. When worn, they subtly fit themselves to the wearer and grant him +2 Dexterity.

After three days of wear, the gloves send out vines that wrap around the users arms but can still be removed with some effort. If not removed, they grant the user a +5 circumstance bonus to Survival checks.

After one week of wear, the wearer of the gloves will discover bark growing on his skin and tiny leaves sprouting on his head. The gloves may still be removed at this point, which negates all effects and bonuses. If not removed, the wearer gains regeneration 1 (fire does lethal damage) and a +2 natural AC bonus.

After two weeks, the wearer's skin and hair are entirely replaced by rough bark and green leaves. At this point, the gloves become part of the wearer's body and can only be removed with a remove curse. The wearer's natural AC bonus increases to +4. The wearer no longer needs to eat food; instead

he gains sustenance by standing in soil for at least one hour every three days.

LUTE OF EPICS

One of the many odd instruments in the sidhe music room, the Lute of Epics looks like a slender and elongated version of a human lute, inlaid with silver and precious stones. The lute is enchanted with powerful magic that makes its wielder seem like a master storyteller.

Anyone wishing to use the Lute of Epics must have at least 5 ranks in Perform (stringed instruments) in order to even strum it competently. This is enough to unlock the lute's storytelling enchantments. Anyone playing the lute while telling a story immediately becomes a genius at character, timing, plot, and all the elements of a good tale. The wielder gains a +10 bonus to Perform (oratory).

In addition, the performer is able to discern certain facts about his audience, tailoring the performance using this knowledge. Simply by looking at a person while performing with the lute, the lute's wielder immediately knows the rough details of that person's family history, major achievements, greatest fears, and dearest hopes.

If used on the battlefield, the lute increases the inspire courage ability of bards by +1.

BOOK OF SECRETS

This strange manual is kept under lock and key in the sidhe library. In earlier times, the sidhe used it to spy on their enemies and stay one step ahead of Milesian battle plans. The book is enormously large and heavy, with pages numbering in the thousands. Its cover is woven bark, its pages fine vellum. The book contains a listing of every single sentient creature except sidhe within 500 miles of its location, sorted alphabetically. Whenever a creature enters or leaves the 500 mile radius, the book changes accordingly; when the Underhill Court teleports, the entire book is altered.

Underneath the names of each of these sentient beings is a short, handwritten account of their deepest secrets. They read as if written by the creatures themselves, and they are always accurate. The secrets themselves vary widely in content. In one entry, a peasant farmer might admit to committing adultery; in another, an old treant might confess to causing the death of a tree he was protecting.

COIN OF LIGG

The sidhe are, in many ways, a superstitious race. This coin is typical of the kind of baubles the sidhe commonly carry around on their person for good luck.

The coin is made of silvron, minted in the ancient days of the Tuatha de Danann. Coins such as this featured the symbols of various different deities and were believed

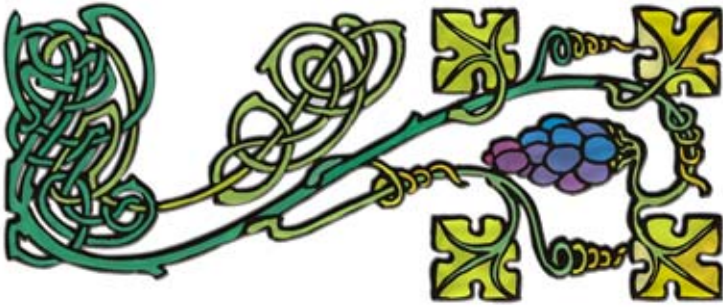

to bring their owners fortune and happiness.

This coin in particular is dedicated to the multi-talented warrior god Ligg. It features a bright sunburst on one side and a sling (Ligg's favored weapon) on the other. The owner of the coin may flip it once daily, at the break of dawn. The results are as follows:

Coin of Ligg flip results (d100 roll)

1-49	Sun side. Owner gains +1 Charisma for 24 hours.
50-99	Sling slide. Owner gains +1 Dexterity for 24 hours.
100 gains	Coin lands on its edge. Owner gains +2 Dexterity and +2 Charisma for 24 hours.

RAVEN MASK

The masks worn by the nightly sidhe guests are often magical in nature. This mask, in the likeness of a raven, is typical of the masks worn by the intellectual class of sidhe nobles.

The raven mask enhances its wearer's memory and erudition, granting him a +5 enhancement bonus to Knowledge (history) and an always-on read magic effect.

BADGER MASK

This mask, in the likeness of a smiling badger, is an example of the kind of magical masks worn by the aesthete class of sidhe.

The badger mask gives its wearer a +5 enhancement bonus to Perform (dance). In addition, anyone the wearer speaks to is considered to be under the effects of a charm person spell cast by the wearer.

THE PANOPLY OF SEASONS

This set of ceremonial attire was created for yearly meetings between the rulers of different sidhe hill tribes. It was traditionally worn by the king whose court hosted the meeting. The sidhe empire, however, was pulled apart by bitter disagreement and envy, and the four pieces of the panoply were separated and scattered to the four winds.

Currently, Lord Auberon keeps the Red Branch of Summer locked away in his private quarters within the Underhill Court. The Shade Staff of Autumn is in the hands of a powerful Milesian sorcerer who nurtures dreams of ruling a united Milesian kingdom. The Black Crystal of Winter lies at the bottom of a perpetually-frozen lake in lands far to the north. Finally, the Dawnflower of Spring is venerated as a holy relic by a community of human monks who keep it in a secret mountain monastery.

Red Branch of Summer:

This leafy redwood branch never seems to wilt or lose its leaves. The

branch functions as a rod of enemy detection. During the season of summer, the rod also grants its wielder +2 Constitution and functions as a wand of fireball (6th).

Shade Staff of Autumn:

This gnarled and knotted staff of yew wood acts as a staff of woodlands. In the season of autumn, however, it also grants its wielder the effects of a ring of feather fall, as well as +2 Wisdom.

Black Crystal of Winter:

This crystal is jet black and freezing cold to the touch. It is attached to a slim silvron chain and can be worn around the neck, in which case it acts as an orb of storms. During the season of winter, it also grants its wearer +2 Intelligence and allows its wearer to cast cone of cold 1/day as a spell-like ability.

Dawnflower of Spring:

This delicate golden flower is perpetually in bloom, never fading or wilting. If damaged, it becomes whole again in a matter of hours. When woven into the hair, the wearer of the flower gains regeneration 1. During the season of spring, the wearer also receives +2 Charisma and may cast plant growth at will as a spell-like ability. If the four items of the panoply are ever brought together by one person, that person will gain the benefits of the season-specific effects of all four items, no matter what season it currently is.

THE PIT MONSTERS

The sidhe warriors who guard the fighting pit have access to a wide



variety of monstrous creatures waiting to be unleashed on hapless victims. The monsters come from all over the known world. Some are fed and groomed every day, while others are so dangerous that they are kept in magical stasis until their big fight. The sidhe tend to choose monsters that are unintelligent or evilly-aligned; they also usually choose ground-based creatures, so as to stop any of them from leaping or flying out of the pit.

Any unfortunate human thrown into the pit will most likely be allowed the use of his own arms and armor; or, if he has none, he will be allowed to choose from a selection. After all, it's just no fun if they don't put up a good fight.

The tables indicate two different sets of possibilities for monsters that may be encountered in the fighting pit. Choose which table to use based on the level of PC involved, if there is more than one PC fighting in the pit, etc.

Easy Pit Monsters Encounter Table (d20 roll)

1-3	1d3 ogres
4-6	1d2 cockatrices
7-9	1d3 dire apes
10-11	1d4+1 bugbears
12-13	1d2 dire boars
14-15	1 basilisk
16-17	1 troll
18-19	1 ettin
20	1 shambling mound

Hard Pit Monster Encounter Table (d20 roll)

1-3	1d4 owlbears
4-6	1d2 manticores
7-9	1d3 minotaurs
10-11	1 dragonne
12-13	1 gray render
14-15	1 dire tiger
16-17	1 spirit naga
18-19	1 nessian warhound
20	1 gorgon



Beyond the Court

The presence of the Underhill Court has a major effect on the land. As soon as it appears, the Court begins subtly changing its forest surroundings. These changes ripple out to affect nearby human settlements.

What follows is a timeline showing possible events centered around the appearance of the Underhill Court.

SUMMARY OF EVENTS TIMELINE

Early Summer: The Court appears, woodwose manifest.

High Summer: Wild Hunt appears, woodland creatures become restless, slough venture forth.

Late Summer: Settlements within 10 miles affected.

Early Autumn: Settlements within 20 miles affected, woodland fey become restless.

High Autumn: Settlements within 10 miles attacked. Fir Bolg and Milesians appear. Treants become active.

Late Autumn: Settlements within 20 miles attacked. Court disappears.

Early Winter: Court appears, woodwose manifest.

High Winter: Wild Hunt appears, woodland creatures become restless, slough venture forth.

Late Winter: Settlements within 10 miles affected.

Early Spring: Settlements within 20 miles affected, woodland fey become restless, yearly monster hunt.

High Spring: Settlements within 10 miles attacked. Fir Bolg and Fomorians appear. Dryads become active.

Late Spring: Settlements within 20 miles attacked. Court disappears.

A more detailed explanation of the twelve different seasonal phases follows:

EARLY SUMMER

On the eve of Brightfires, the Underhill Court materializes in a random forest somewhere in the world. During this season, the woodwose creation magic takes effect, calling forth the souls of nearby trees. These souls become the woodwose, the first guardians of the Court. At this point, the woodwose will not venture further than a few miles from the Court's location.

HIGH SUMMER

During this phase, Herne and the Wild Hunt first appear. At first they hunt infrequently and close to home, but over the coming months they grow bolder. By the end of autumn, the Wild Hunt will occur every night, often roaming 8-10 miles away from the Court.

Also in this phase, the native creatures of the forest begin to act strangely, their minds altered by the Court's presence. Wolves bay and howl constantly, bears attack hunters in their cabins, owls swoop down and steal belongings, etc.

In this phase, the slough begin to venture out of the Court at night in search of food for the kitchens or interesting items to bring back to their masters.

LATE SUMMER

At this point, human settlements within 10 miles of the Underhill Court begin to experience strange phenomena. They may see lights in the sky above the forest, hear eerie pipe music coming from holes in the ground, or experience terrifyingly vivid dreams of ancient battlefields. Human hunters may be led on wild goose chases by phantom stags or lured away by dancing lights.

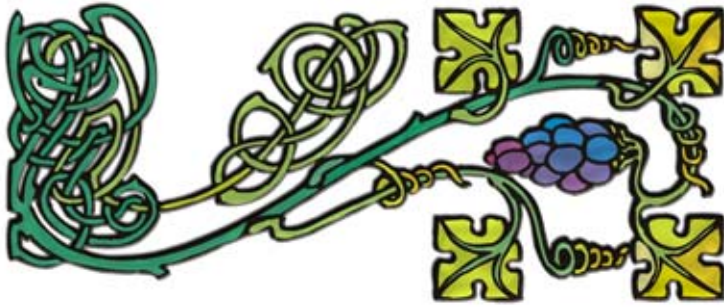

EARLY AUTUMN

In this phase, settlements within 20 miles experience the same strange events.

Also, small forest-dwelling fey such as grigs, nixies, and pixies begin trooping around the forest in large bands, possibly harassing human settlements.

HIGH AUTUMN

During this phase, settlements within 10 miles of the Court are attacked by roving groups of woodwose and fey. Their goal is usually to steal interesting items and to destroy or carry away anything made of iron. They also destroy or deface any human churches they come across, as per Lady Titania's orders (the Lady believes the humans should be made to remember the rightful ancient gods of the land, the Tuatha de Danann). These attacks mostly occur at night and may happen as often as twice a week unless met with strong resistance.

At this time, small tribes of the sidhe's great enemies – the Fir Bolg and Milesians – appear in the forest. These dangerous giants search the countryside for the location of the Underhill Court, but are usually led away from it by devious woodland fey.

If these tribes do enter the forest, their depredations will be noticed. Ancient treants awaken to confront them and there may be running battles between the giants and the protectors of the forest.

LATE AUTUMN

Settlements within 20 miles suffer the same sort of attacks as mentioned in the last phase. Finally, at the end of this phase, the Underhill Court disappears and reappears in a new location somewhere in the world.

EARLY WINTER

Same as Early Summer.

HIGH WINTER

Same as High Summer.

LATE WINTER

Same as Late Summer.

EARLY SPRING

Same as Early Autumn. In addition, the sidhe conduct their yearly hunt for new monsters for the fighting pit. As many as 20 sidhe warriors accompany the expedition, which can last up to 3 days. Occasionally, Lord Auberón personally leads the hunt.

HIGH SPRING

Same as High Autumn, except with Fomorians instead of Milesians and dryads in place of treants.

LATE SPRING

Same as Late Autumn.



Map of the Court

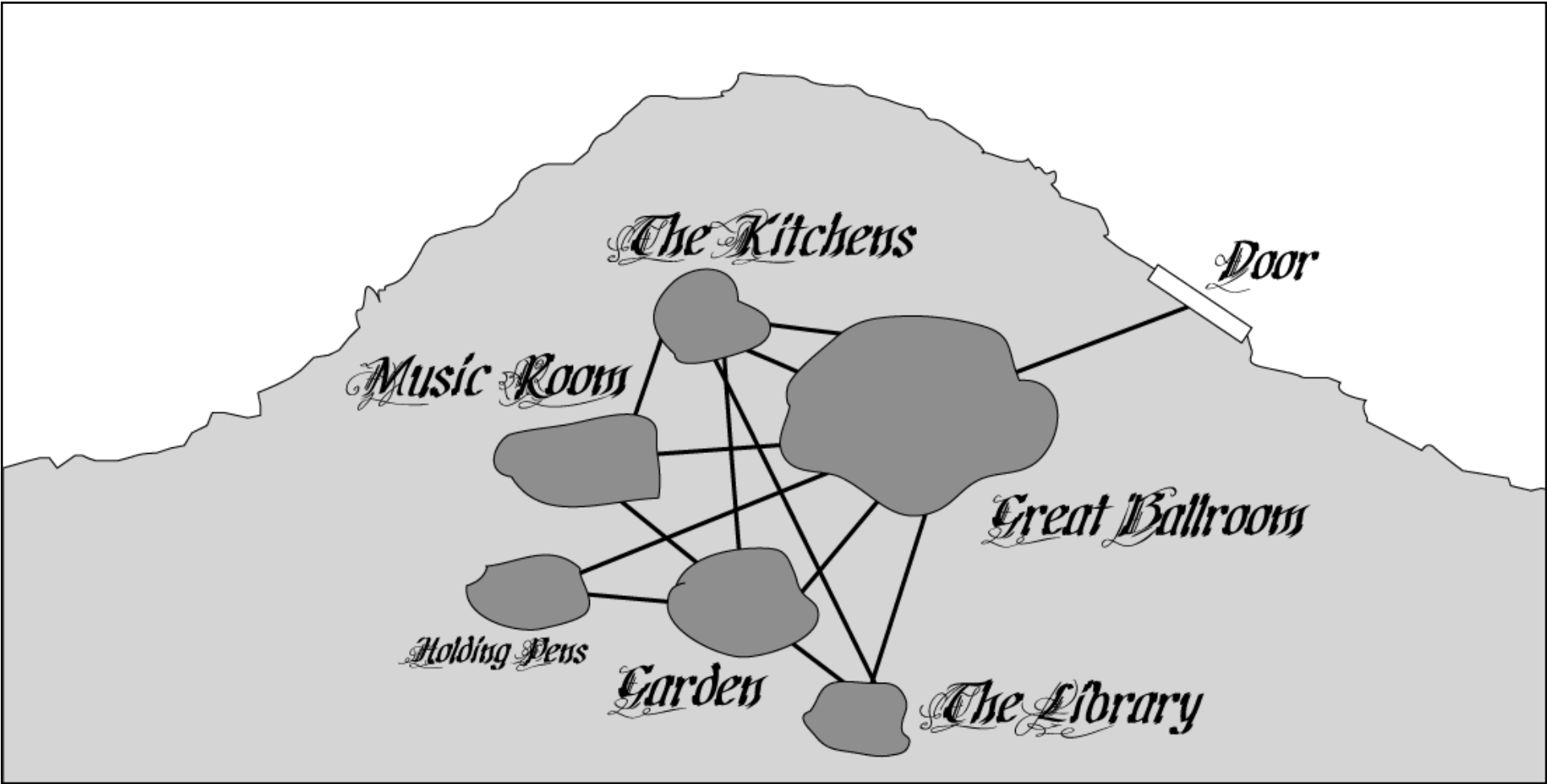

Map of the Ballroom

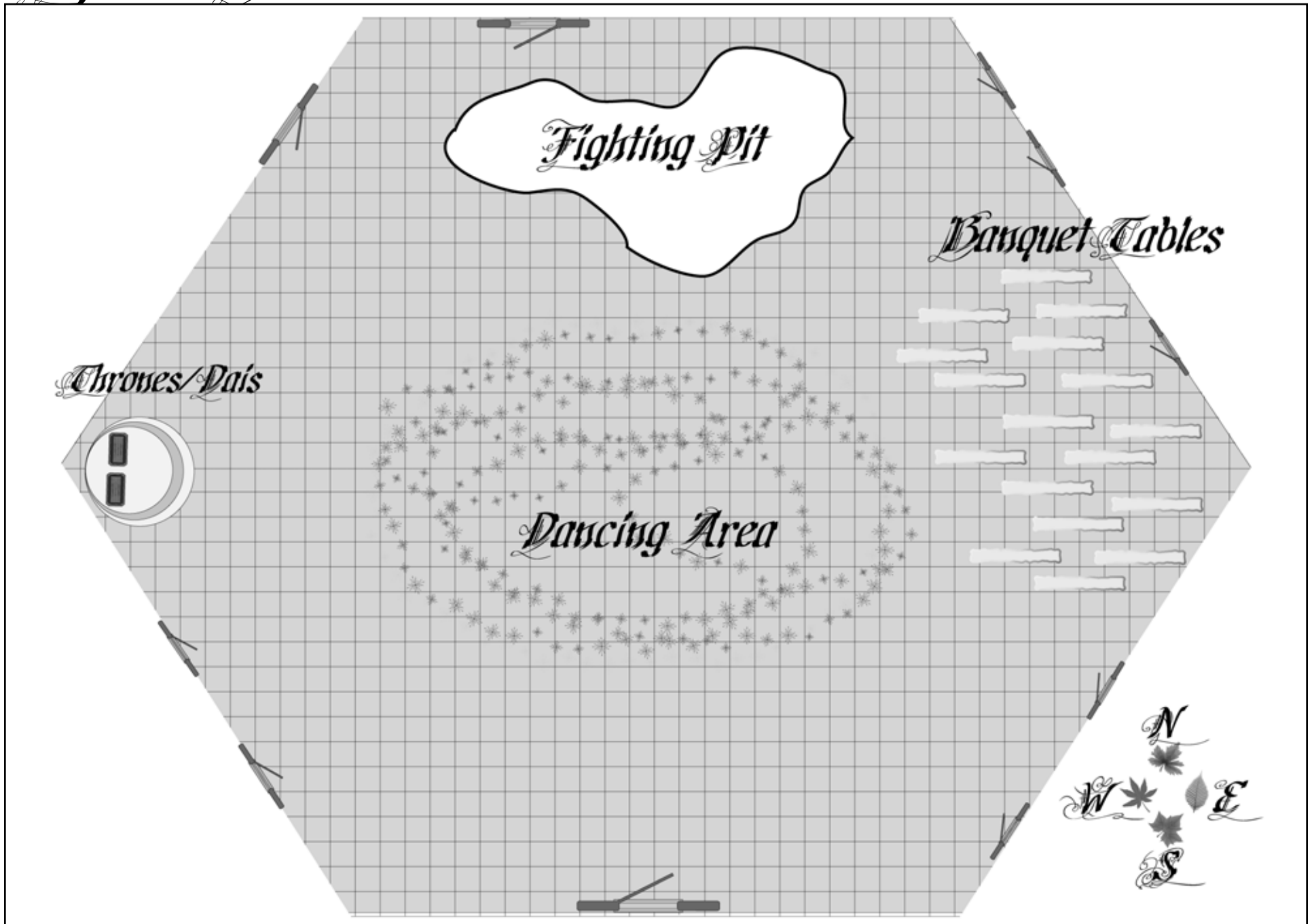

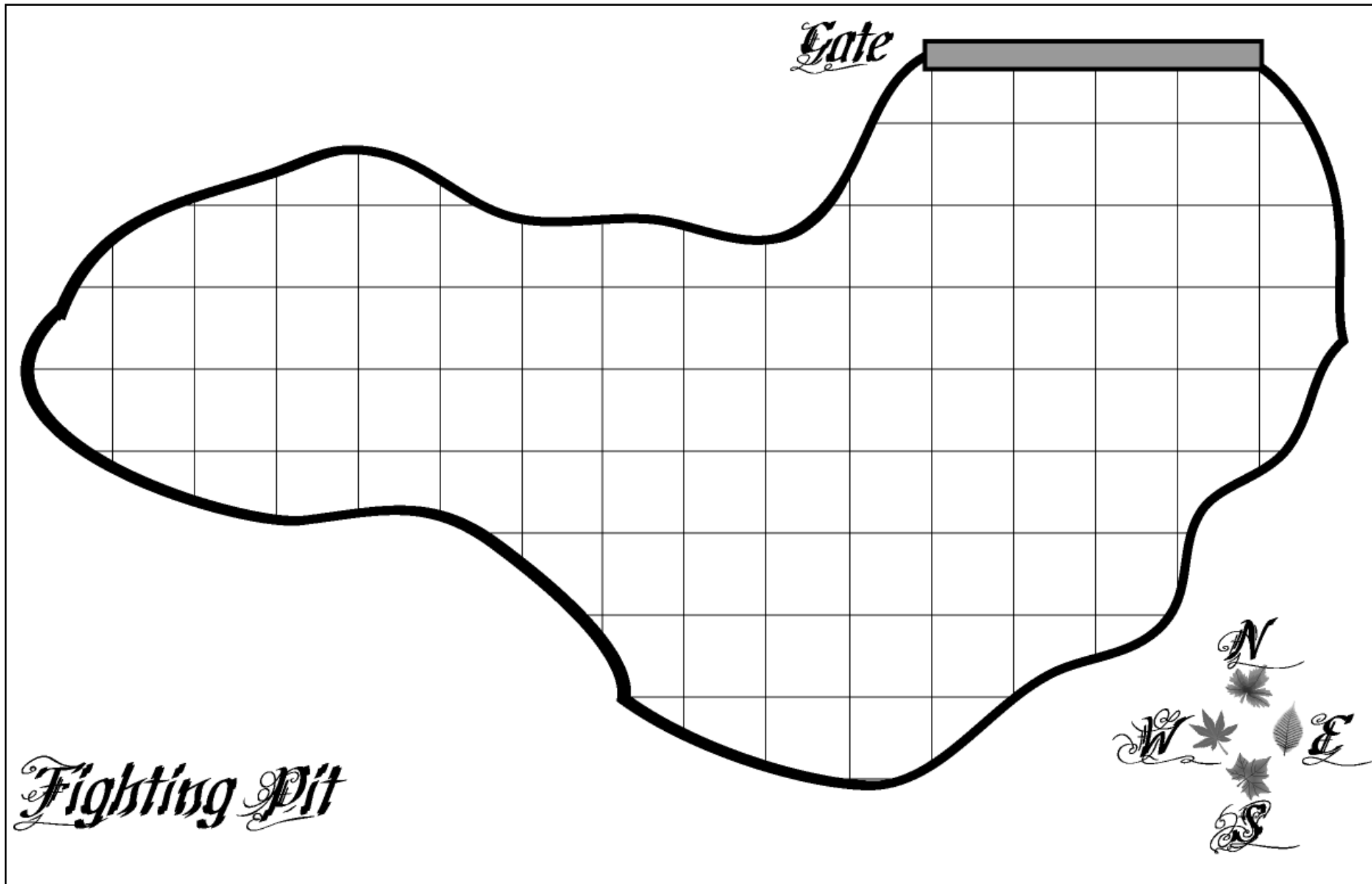

Stats

This section presents game statistics for several NPCs and items of the Underhill Court.

If PCs did attempt combat with Auberon or Titania, they have very little chance of survival. If they actually do have a chance, the GM would be perfectly within his or her rights to simply teleport them out of the Underhill Court and have the hill entrance disappear.

LORD AUBERON

Sidhe Male Fighter 7/Ranger 7/Sorcerer 6

CR 22; Medium-size humanoid; hp 158; Init +8; Spd 30 ft.; AC 23, touch 14, flat-footed 19; BAB +17/+12/+7/+2; Grp +22; Atk Spear of Danu +26/+21/+16/+11 melee (1d8+9, x3) or Wrath of the Silver Hand +27/+22/+17/+12 ranged (1d8+1, x3); Space/Reach 5 ft./5 ft., or 10 ft./10ft. with spear; SA None; SQ Damage reduction 10/iron, regeneration 5 (iron weapons do lethal damage), woodland stride, wild empathy, 1st favored enemy: giants, 2nd favored enemy: humanoids (humans); AL CG; SV Fort +16, Ref +13, Will +15; Str 20, Dex 18, Con 18, Int 19, Wis 18, Cha 20.

Languages: Sidhe, Sylvan, Milesian, Fir Bolg, Fomorian, Common.

Skills and Feats: Bluff +13, Climb +15, Concentration +10, Craft (weaponsmithing) +12, Craft (armorsmithing) +12, Diplomacy +19, Handle Animal +29, Heal +10, Hide +10, Intimidate +21, Jump +15, Knowledge (arcana) +12, Knowledge (nature) +16, Listen +10, Move Silently +9, Ride +31, Search +10, Sense Motive +6, Spellcraft +12, Spot +10, Survival +11, Swim +11; Animal Affinity, Leadership, Negotiator, Iron Will, Improved Initiative, Power Attack, Cleave, Great Cleave, Mounted Combat, Mounted Archery, Rideby Attack, Spirited Charge, Track, Rapid Shot, Endurance, Manyshot.

Spells: Ranger spells per day: 2 x 1st level spells.

Sorcerer spells per day: 6 x 0th level, 8 x 1st level, 6 x 2nd level spells, 4 x 3rd level spells.

Ranger spells known: Knows all 1st level ranger spells.

Sorcerer spells known : 0th:All. 1st: cause fear, charm person, comprehend languages, unseen servant. 2nd: bull's strength, invisibility. 3rd: summon monster III.

Equipment: silvrn scale mail +5, greater bracers of archery, Spear of Danu (magical long spear +4), Wrath of the Silver Hand (silvrn composite longbow +4).

New items

Spear of Danu: This incredibly ancient weapon is made from the wood of the first oak tree, planted by the mother goddess Danu. Despite its simple appearance, it has immense power over nature. The spear normally functions as a defending spell-storing longspear +4. However, when it is stood upright in the soil and a prayer to Danu is spoken, the wielder may make use of the spear's other powers: control weather 1/day, move earth 3/day and wall of thorns 5/day.

Wrath of the Silver Hand: This longbow is a thing of beauty, given to Auberon by the god Nuadhu. It is a brilliant energy seeking composite longbow +4 which also grants its wearer the use of stonesskin 3/day. The magical skin created by the stonesskin spell appears to be made of shining liquid silver. Note: In Auberon's case, the stonesskin spell alters his damage reduction so that he is no longer vulnerable to iron.

LADY TITANIA

Sidhe Female Sorcerer 16/Bard 4

CR 22; Medium-size humanoid; hp 140; Init +5; Spd 30 ft.; AC 15, touch 15, flat-footed 10; BAB +11/+6/+1; Grp +14; Atk dagger of venom +15/+10/+5 melee (1d4+4, 19-20 x2); Space/Reach 5 ft./5 ft.; SA None; SQ Damage reduction 10/iron, regeneration 5 (iron weapons do lethal damage), bardic music, bardic knowledge, countersong, fascinate, inspire courage +1, inspire competence; AL CN; SV Fort +14, Ref +18, Will +22; Str 16, Dex 20, Con 18, Int 18, Wis 18, Cha 21 (25 with rod of splendor).

Languages: Sidhe, Sylvan, Milesian, Fir Bolg, Fomorian, Common.



HERNE THE HUNTER

Sidhe Male Barbarian 8/Ranger 7

Skills and Feats: Bluff +25, Concentration +24, Craft (painting) +19, Craft (calligraphy) +19, Decipher Script +24, Diplomacy +17, Gather Information +11, Intimidate +7, Knowledge (arcana) +25, Knowledge (nobility and royalty) +10, Listen +10, Perform (string instruments) +13, Sense Motive +10, Sleight of Hand +7, Spellcraft +28, Use Magic Device +11; Brew Potion, Combat Casting, Empower Spell, Eschew Materials, Greater Spell Penetration, Maximise Spell, Silent Spell, Craft Magic Arms and Armor, Spell Penetration.

Spells: Sorcerer spells per day: 6 x 0th level, 8 x 1st level, 7 x 2nd level spells, 7 x 3rd level spells, 7 x 4th level spells, 7 x 5th level spells, 6 x 6th level spells, 5 x 7th level spells, 3 x 8th level spells.

Sorcerer spells known : 0th: All. 1st: cause fear, charm person, mage armor, protection from law, ray of enfeeblement. 2nd: detect thoughts, invisibility, mirror image, tasha's hideous laughter, web. 3rd: fly, hold person, lightning bolt, suggestion. 4th: dimension door, lesser geas, phantasmal killer, wall of ice. 5th: blight, dominate person, permanency. 6th: control weather, geas/quest, summon monster VI. 7th: forcecage, phase door. 8th: polymorph any object.

Equipment: cloak of resistance +4, rod of splendor, dagger of venom, Mask of the Queen.

New items

Mask of the Queen: This is a masquerade-style half-mask in the likeness of a vicious she-lion. It has no straps or string; rather it is mounted on a stick, allowing it to be held up to the face. When looking through the mask, the wearer experiences the benefits of detect thoughts and discern lies. These effects are always on. Titania often uses the mask when she suspects someone is not being wholly truthful with her. Detection of even the smallest lie usually leads to dire consequences for the liar.

CR 16; Medium-size humanoid; hp 142; Init +3; Spd 30 ft.; AC 17, touch 13, flat-footed 14; BAB +15/+10/+5; Grp +19; Atk Spear of the Hunt +22/+17/+12 melee (1d8+7, x3) or composite longbow +2 +20/+15/+10 ranged (1d8+4, x3); Space/Reach 5 ft./5 ft., or 10 ft./10ft. with spear; SA None; SQ Damage reduction 10/iron, regeneration 3 (iron weapons do lethal damage), fast movement, rage 3/day, uncanny dodge, improved uncanny dodge, trap sense +2, woodland stride, wild empathy, 1st favored enemy: giants, 2nd favored enemy: humanoids (humans); AL CE; SV Fort +16, Ref +11, Will +4; Str 18, Dex 16, Con 18, Int 14, Wis 11, Cha 14.

Languages: Sidhe, Sylvan, Milesian, Fir Bolg, Fomorian, Common.

Skills and Feats: Climb +12, Handle Animal +22, Intimidate +20, Jump +22, Knowledge (nature) +10, Listen +11, Ride +25, Survival +23, Swim +16; Animal Affinity, Combat Reflexes, Great Fortitude, Improved Critical (longspear), Mounted Combat, Mounted Archery, Rideby Attack, Track, Rapid Shot, Endurance, Manyshot.

Equipment: silvrion scale mail, Spear of the Hunt (magical long spear), silvrion composite longbow +2.

New items

Spear of the Hunt: This long spear +3 appears to be made of dark ash wood. Its haft is entwined with vines, and its pointed end is always bloodied. It grants the wielder a +5 circumstance bonus to all tracking-related Survival checks. If the wielder does not have the Track feat, he is granted the Track feat for as long as he possesses the spear.

SIDHE WARRIOR

Sidhe Male Fighter 7

CR 7; Medium-size humanoid; hp 66; Init +6; Spd 20 ft.; AC 16, touch 12, flat-footed 14; BAB +7/+2; Grp +9; Atk scimitar +9/+4 melee (1d6+2, 18-20/x2); Space/



Reach 5 ft./5 ft.; SA None; SQ Damage reduction 10/iron; AL CN; SV Fort +6, Ref +4, Will +2; Str 14, Dex 15, Con 13, Int 13, Wis 10, Cha 12.

Languages: Sidhe, Common.

Skills and Feats: Climb +8, Craft +6, Escape Artist +4, Handle Animal +9, Intimidate +9, Jump +7, Ride +8, Swim +6; Agile, Blind-fight, Combat Expertise, Improved Disarm, Improved Feint, Improved Trip, Dodge, Improved Initiative.

Equipment: silvron scale mail, silvron scimitar, light shield.

Description: The typical sidhe warrior looks like a tall, pale-skinned human with slightly elongated features and cat-like eyes. In full silvron armor, they are often dazzling to look upon. Some sidhe warriors wear silvron masks in the likeness of laughing or crying faces.

The statistics for the sidhe warrior are for an average sidhe guarding the Underhill Court; they may in fact be male or female, and may vary in level.

SLUAGH

CR 4; Medium-size undead (incorporeal); Hit Dice 3d10 (16 hp); Init +5; Spd 40 ft., fly 80 ft.; AC 15 (+3 Dex, +2 deflection), touch 15, flat-footed 13; BAB +3; Grp –; Atk incorporeal touch +4 melee (1d4 plus magic drain); Space/Reach 5 ft./5 ft.; SA Magic drain; SQ Darkvision 60 ft., incorporeal traits, undead traits; AL N; SV Fort +2, Ref +4, Will +6; Str –, Dex 16, Con –, Int 10, Wis 10, Cha 14.

Languages: Sidhe, Milesian.

Skills and Feats: Hide +9, Intimidate +8, Listen +10, Search +8, Spot +10. Blind-fight.

Combat: A slugh will only strike in

self-defense. It targets magic-users first with its magic drain. If outnumbered, slugh will retreat and seek help.

Magic drain (Su): If a slugh's incorporeal touch hits a magic-using creature, that creature must pass a Will save (DC 20) or immediately lose one of its spells per day or memorised spells (chosen randomly).

Description: Slugh take the form of incorporeal, barely-visible humanoids, their features distorted and elongated. Their eyes have a dull reddish glow, and their hands are twisted into long, transparent talons.

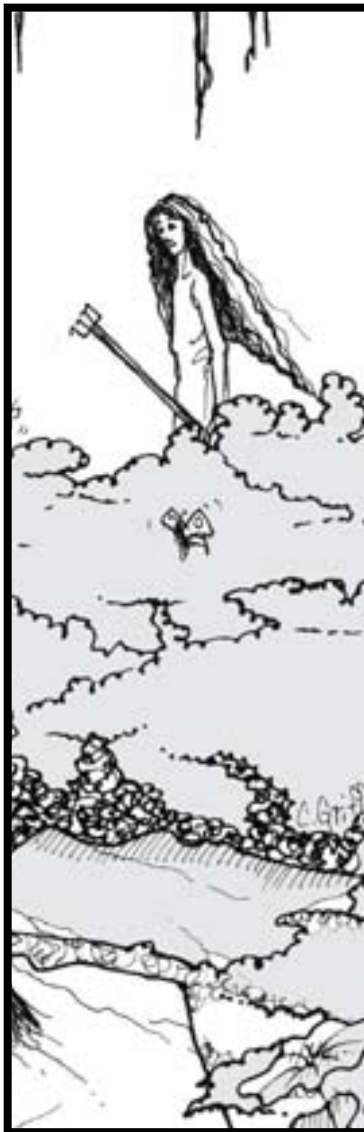

On first glance, most people believe slugh to look like distorted, ghostly sidhe. Those familiar with the Milesians will notice in the slugh certain peculiarities – the bridge of the nose, the tint of the skin – that call to mind this race of giants.

WOODWOSE

CR 5; Medium-size humanoid; Hit Dice 3d12 (18 hp); Init +3; Spd 30 ft.; AC 15 (+2 Dex, +3 natural), touch 12, flat-footed 13; BAB +3; Grp +5; Atk claws +5 melee (1d6+2); Space/Reach 5 ft./5 ft.; SA Spell-like abilities; SQ Low-light vision, wood-walking; AL N; SV Fort +2, Ref +4, Will +1; Str 15, Dex 14, Con 13, Int 10, Wis 10, Cha 16.

Languages: Sidhe, Sylvan.

Skills and Feats: Climb +5, Hide +6, Listen +4, Move Silently +6, Spot +4. Dodge.

Combat: Woodwose prefer ambushes and hit-and-run tactics to direct confrontation. They aim to scare and confuse their opponents.



Spell-like abilities: 1/day – dancing lights, detect chaos, detect good, detect evil, detect law, entangle (DC 15).

Wood-walking (Su): As a move action, a woodwose may step into a nearby tree of medium-size or greater as if it were intangible. Once inside a tree, the woodwose is impervious to harm. As a move action, the woodwose may then step out of any medium-size or greater tree within 50 feet.

Description: At first, woodwose look something like miniature treants, wrapped in leafy vines and verdant green. On closer inspection, they actually appear closer to humans in shape and facial features. Their skin is the smooth green of new grass, their teeth and claws are solid wood, and they bear an aroma of tree sap. Their faces are frozen in a perpetual laughing grin. Oddly, woodwose feel solid enough, and yet they move through the forest like incorporeal beings, stepping through plants as if they weren't there.

FIR BOLG

CR 8; large giant; Hit Dice 9d8+54 (94 hp); Init +3; Spd 40 ft.; AC 19 (-1 size, +3 Dex, +6 natural, +1 padded), touch 13, flat-footed 16; BAB +6; Grp +18; Atk club +14 melee (1d10+8); Full Atk club +14/+12/+7 melee (1d10+8); Space/Reach: 10 ft./10 ft.; SA Frightful presence; SQ Low-light vision, spell resistance 19; AL CE; SV Fort +14, Ref +6, Will +2; Str 27, Dex 17, Con 23, Int 12, Wis 9, Cha 8.

Languages: Fir Bolg.

Skills and Feats: Balance +3, Climb +14, Escape Artist +3, Hide -1, Intimidate +9, Jump +8, Listen -1, Move Silently +3, Sleight of Hand +3, Spot +9, Survival +4, Swim +13, Tumble +3; Great Fortitude, Improved Bull Rush, Power Attack, Track.

Equipment: great club, padded armor.

Frightful Presence (Ex): This special quality makes a

Fir Bolg's very presence unsettling to foes. It takes effect automatically when the Fir Bolg first attacks in combat. Opponents within 30 feet who witness the attack may become frightened or shaken for 5d6 rounds. This ability affects only opponents with fewer Hit Dice or levels than the Fir Bolg. An affected opponent can resist the effects with a successful Will save (DC 13). An opponent that succeeds on the saving throw is immune to that same creature's frightful presence for 24 hours. Frightful presence is a mind-affecting fear effect.

Spell Resistance (Ex): A creature with spell resistance can avoid the effects of spells and spell-like abilities that directly affect it. To determine if a spell or spell-like ability works against a creature with spell resistance, the caster must make a caster level check (1d20 + caster level). If the result equals or exceeds the creature's spell resistance, the spell works normally, although the creature is still allowed a saving throw.

Description: Fir Bolg are twisted and hideous-looking giants, with bestial, pig-like faces. They are loathsome and hate-filled; motivated purely by avarice, they seek out gold, magic, and baubles with which to adorn themselves. The leader of a Fir Bolg clan is always the one with the most wealth.

Fir Bolg despise sunlight, choosing to venture out only during the night if possible. Despite their negative qualities, Fir Bolg are cunning hunters with a natural resistance to magic. They enjoy attacking the settlements of weaker races, upon which they can make full use of their frightful presence ability. When raiding in search of sidhe, the Fir Bolg are smart enough to always use iron weapons.

Fir Bolg build crude cities in great underground caverns, away from harsh daylight. They usually attack any likely sentient communities within striking distance, and they are not averse to the taking and keeping of slaves. But the Fir Bolg are not the most organized of races, and they themselves are occasionally enslaved by the more advanced Fomorian or Milesian giants.



FOMORIAN

CR 8; large giant (fire); Hit Dice 9d8+54 (94 hp); Init +3; Spd 30 ft.; AC 22 (-1 size, +3 Dex, +7 natural, +3 hide), touch 13, flat-footed 19; BAB +6; Grp +18; Atk greataxe +14 melee (1d12+8, x3); Full Atk club +14/+9/+4 melee (1d12+8, x3); Space/Reach: 10 ft./10 ft.; SA None; SQ Fast healing 4, low-light vision, scent; AL CN; SV Fort +12, Ref +6, Will +4; Str 27, Dex 17, Con 23, Int 14, Wis 12, Cha 14.

Languages: Fomorian, Sidhe.

Skills and Feats: Climb +11, Hide -4, Intimidate +8, Jump +11, Knowledge (nature) +8, Listen +7, Sense Motive +7, Spot +7, Survival +7, Swim +2; Improved Bull Rush, Power Attack, Awesome Blow, Blindfighting.
Equipment: greataxe, hide armor.

Fast Healing (Ex): Fomorians gain 4 hit points per round. Fast healing does not restore hit points lost from starvation, thirst, or suffocation, and it does not allow the Fomorian to regrow lost body parts.

Fire Subtype: Fomorians are immune to fire. However, they are vulnerable to cold, which means they take half again as much (+50%) damage as normal from cold, regardless of whether a saving throw is allowed, or if the save is a success or failure.

Description: Fomorians look like ape-like giants covered in a fuzzy layer of fur ranging in color from deep red to pale brown. Their faces are almost human, and quite noble in appearance.

The Fomorians come from a hot desert land to the south, where they bury themselves in the sand to escape the heat of the day. For this reason, they only pursue their sidhe enemies during the warmer months of the year. When Fomorians come seeking sidhe to fight, they make sure to bring weapons of iron.

Fomorians are nomads by nature, living in small communities and always on the move. The tribe is traditionally led by the mightiest hunter, in accordance

with ancient Fomorian laws of honor. These are actual codified laws, passed down orally through the generations. They state that a Fomorian's greatest asset is his honor, and that great honor can be gained from defeating a powerful enemy on the field of battle.

The harsh existence of the Fomorians has produced a hardy race in tune with every one of its senses. Fomorian hunters are renowned for their ability to sniff out prey, and sidhe rightly fear the giants' miraculous healing qualities.

MILESIAN

CR 9; large giant (frost); Hit Dice 10d8+70 (115 hp); Init +5; Spd 40 ft.; AC 29 (-1 size, +4 Dex, +10 natural, +4 chain shirt, +2 heavy steel shield), touch 14, flat-footed 25; BAB +7; Grp +18; Atk longbow +12 ranged (1d6, x3) or warhammer +14 melee (1d8+7, x3); Full Atk longbow +12/+7 ranged (1d6, x3) or warhammer +14/+9/+4 melee (1d8+7, x3); Space/Reach: 10 ft./10 ft.; SA None; SQ Damage reduction 10/magic, low-light vision; AL CE; SV Fort +14, Ref +7, Will +4; Str 25, Dex 21, Con 25, Int 16, Wis 12, Cha 14.

Languages: Milesian, Sidhe.

Skills and Feats: Bluff +12, Climb +3, Hide -4, Intimidate +12, Jump +13, Knowledge (arcana) +8, Listen +11, Spot +1, Survival +11, Swim +35; Dodge, Mobility, Spring Attack, Whirlwind Attack.

Equipment: longbow, warhammer, chain shirt, heavy steel shield.

Frost Subtype: Milesians are immune to cold. However, they are vulnerable to fire, which means they take half again as much (+50%) damage as normal from fire, regardless of whether a saving throw is allowed, or if the save is a success or failure.

Description: The Milesians are a cruel and wicked race of northern seafarers who sweep down out of the north to raid and pillage the other races of the



world. They look like enormous bearded humans with ice-white skin and snarling, angry features. They radiate cold, and their breath is ice.

Most Milesians are warriors, but they also seem to produce a great many sorcerers. These northern spell-casters tend to be the leaders of tribes by virtue of their strength in the magical arts. Tribal leaders also communicate with each other through magical messages, coordinating their attacks; in this sense, the Milesians can be said to be ruled by a loose mageocracy.

In the colder months, the Milesians beach their great longboats and send raiding parties out to look for their old enemies, the sidhe. They seek bloody revenge for the losses their race suffered in ancient battles, and giants tend to have long and spiteful memories. Of course, they make all their raiding weapons out of iron, the metal their hated enemies fear most.

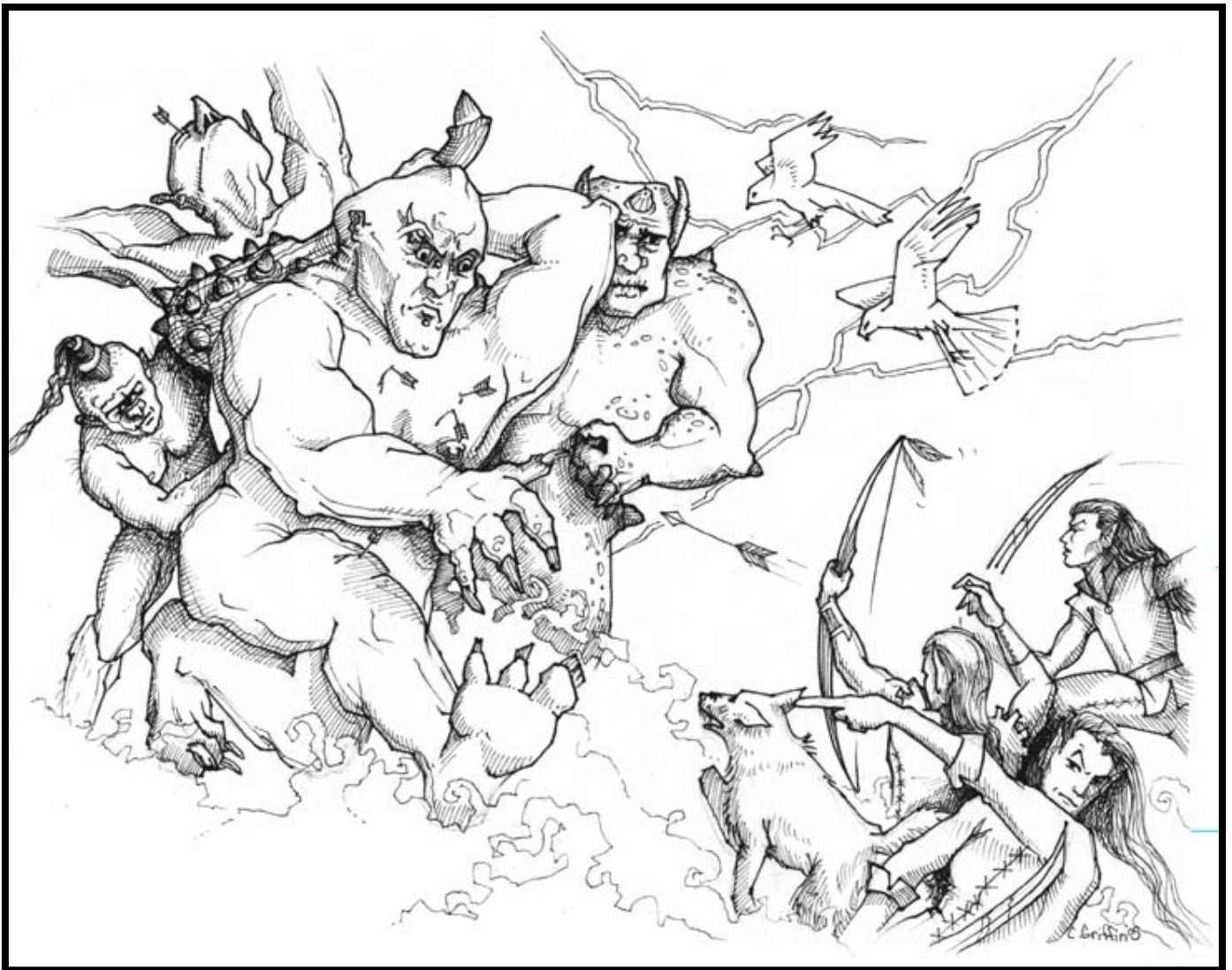

Sample Dialogue

LADY TITANIA

'You wish to talk with me? Very well. This music bores me, and you might provide a momentary diversion. Talk about me? Well, what an unctuously polite little mortal you are. The truth is, everyone in this room fears me. With but a single word, I could have any of them – even you, little mortal – thrown into the pit to have their limbs individually pulled off. Fear is a wonderful thing, isn't it? And so they fear me, but they also love me, for I am fair and kind. And quite pretty too. Don't you agree?'

Auberon: 'I have nothing to say about that.'

The jester: 'Little Puck remains the most amusing thing to ever happen to this whole dreary court. I'm sure he has a few cutting things to say about your slovenly appearance...'

The nightly guests: 'Vultures, snakes, and weasels. Even now, they are plotting their way into my favor. I'm wise to them, human, as I am wise to you.'

Herne: 'You should not be so hasty to concern yourself with our business.'

The PCs: 'Humans don't interest me as much as they once did. There was a time when I couldn't get enough of your

playful antics and frantically-short-yet-amusing lives. I grew up.'

AUBERON

'You say you know something of battle? I must confess, I've a little experience in the matter of war. Have you ever heard of the Fir Bolg? They were a truly mighty race, but perhaps a little before your time. They roamed these forests around three thousand of your years ago, logging, burning, and building their foul city of iron on our lands. I was but a young warrior when they chose me to lead the expedition to the Fir Bolg's city of black smoke. It was hardly a great battle. My band scaled the city walls and fell upon

them in the night, slaughtering them down to the last grotesque child. We wiped out an entire society and placed their heads on the city walls as a warning. Those were better days...'

Titania: 'My queen. She has never been anything but loyal. What else is there to say?'

The jester: 'Let's just say that he is a friend. He serves to remind me that humor is a powerful weapon, in the right hands.'

The nightly guests: 'Sad to think that they were once my loyal host, my fearful warrior-band. How we have fallen.'

Herne: 'The choices we make ripple forward into our future, affecting our lives. Sometimes, there are terrible consequences. But that is a sidhe matter.'

The PCs: 'When you return, perhaps you could remind the world above of our achievements? Our battles, our conquests... or perhaps not. After all, they'd only forget it in a few centuries.'

THE JESTER

'Listen up! Yeah you, with the gawking face and the funny nose. I got a little proposal for you. These sidhe, all they do is drink and dance. They ain't thinkers, not like you and me. That's why they leave all their treasure unguarded. If you sneak out through that door,

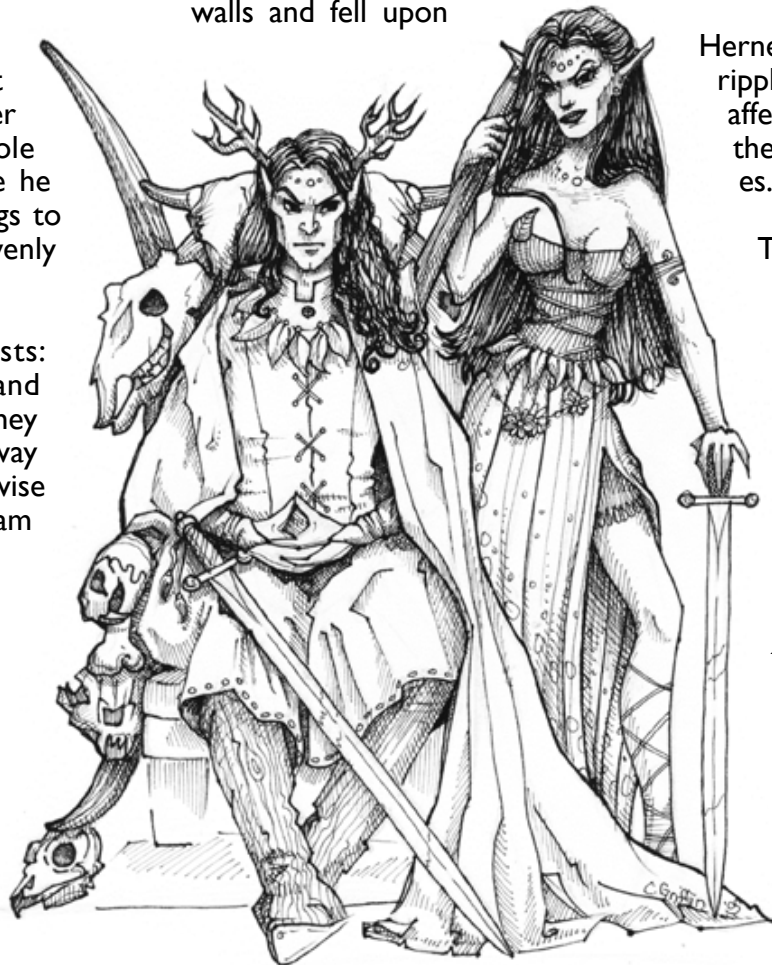

take a left, a right, a left, and a left again, you'll come to the king's treasure chamber! Yep, true as my name's Puck. Just share some of the gold with me when you're rich. Here, make your attempt now. Don't worry, I'll distract 'em with a little song and dance. No, no... thank you, friend.'

Titania: 'Kind-hearted and pretty to look upon. Who'd have imagined it. You'll have no trouble from her, I can tell you now.'

Auberon: 'As decent a king as any I've known. Thing is, he'll always be sizing you up when he's talking to you. Makes you feel a bit small sometimes.'

The nightly guests: 'Endlessly amusing, they are. Take old Camlainn over there in the raven mask. I could tell you stories about him that'd turn your hair white! It was back during the Second Milesian Wars...'

Herne: 'Not the funniest subject. I don't often bring it up 'cause I'd like to keep my job.'

The PCs: 'Oh, ho, ho! Where do I start? How 'bout you, the bald one. Does your mother always put your armor on for you?'

THE NIGHTLY GUESTS

'I say, it's rather interesting having someone from above the hill to speak with. Tell me, do your human priests still sacrifice virgins to their gods? They don't? What a pity. I always did enjoy the spectacle. How about their little wooden forts and stone rings, do they still build those? Oh, that's just as well,

I suppose. I'm glad you've moved on.'

'Pardon me human, but could you help us settle a little bet? It seems like Lady Etain and I have been feuding for decades over which of us possesses the more lovely complexion. If you were to help decide the matter in my favor...'

Titania: 'The radiant queen of our court and object of all our effort and affections.'

Auberon: 'A bit of a stick-in-the-mud, don't you think?'

The jester: 'That scandalous, hairy little ape made fun of my hat last week. I'll show him...'

Herne: 'I wouldn't know, I don't go above ground much. But I hear from one of the guards that he's becoming a problem.'

The PCs: 'You really worship these new-fangled gods? Build shrines and temples to them? Why, when we walked the earth they weren't even born.'

Plot Hooks

FAITH AND MAGIC

A local church is under attack. Strange creatures come in the night and break into the temple; the next day, religious icons are found smashed and iron objects are discovered melted into piles of slag. The PCs are hired to guard the church and eventually they are compelled to track the attackers back to their base of operations: a grassy hill in the middle of the forest. Why are Auberon and Titania

condoning these attacks? Can the PCs heal the wounds between the sidhe and the church?

A PLAGUE OF MONSTERS

Terrible creatures are being driven out of the forest! The PCs must find out what is causing them to flee. Perhaps the woodwose are responsible. If the PCs stumble across the Underhill Court, will they get involved in the sidhe's dealings?

HUNTED BY HERNE

The PCs are travelling in the woods at night when suddenly they find themselves targets of the terrible Wild Hunt. Perhaps they seek refuge in the Underhill Court? If they stand and fight the Hunt, will they discover Herne's true identity?

WORKING FOR AUBERON

This is a multi-part quest idea for PCs of fairly high level.

The start of this quest assumes that the PCs find the Underhill Court, perhaps via A plague of monsters or Faith and magic above. The PCs then get to know the inhabitants of the Court, maybe running a few errands for the nobles.

Next, in order to win the favor of Lord Auberon, the PCs agree to help him search for a traitor that Auberon believes is hiding in the Underhill Court. Auberon has caught wind of a noble of the aesthete group who is trying to drum up support for a coup attempt against the king and queen. If the PCs flush the traitorous sidhe out, he reveals that he has been working for the Milesians. In addition, the Milesians have made a deal

Appendix

(Plot Hooks, continued)
with Herne to use his Wild Hunt against the Court. For the first time in centuries, the Wild Hunt begins attacking sidhe, even besieging the Underhill Court entrance. Auberon asks the PCs to help him defeat Herne (Auberon cannot physically harm Herne himself). If the PCs succeed, Herne's death makes Auberon whole again, but cancels the sorcery that allows the Underhill Court to teleport twice a year. The Court is now at the mercy of the Milesian army, which has finally pinpointed its location.

The PCs must now aid the sidhe in their war against the giants; but there are so few sidhe left. Perhaps the PCs will be sent to seek an alliance with the dangerous Fomorians or Fir Bolg. With these allies, they might stand a chance of driving back the Milesian raiders. Fir Bolgs would be easier to corral into the PCs service, but far harder to control and likely to turn on their leaders at the first opportunity. To reach the Fomorians, the PCs would have to travel far into southern lands. They would then have to prove their honor beyond a doubt before the Fomorians would join the sidhe army.

Finally, this adventure could continue on into even higher-level territory. The PCs might attempt to restore the teleporting magic of the Court, or they may seek out Lord Auberon's ultimate goal: the lost spell of sidhe reproduction. With this spell, they could potentially restore the Tuatha de Danann to their former glory.

PRONUNCIATION GUIDE

Auberon: "ORB-er-on".

Danu: "DAH-noo".

Fir Bolg: "fer bolg".

Fomorian: "foh-MOR-ee-an".

Herne: "HER-nuh".

Milesian: "my-LEE-shan".

Nuadhu: "noo-AH-doo".

Sidhe: "shee".

Sluagh: "slew".

Titania: "tie-TAY-nee-ah".

Tuatha De Danann: "THOO-a-haw-day-DAH-nawn".

COMMON WEAPONS AND ARMOR OF THE SIDHE

Weapons

Sidhe weapons are usually made from either silvrion or wood. In the following lists, (s) indicates weapons that are most often made from silvrion.

Commonly-used simple weapons: dagger(s), sickle(s), shortspear(s), longspear(s), quarterstaff, spear(s), dart, javelin, sling.

Commonly-used martial weapons: handaxe(s), short sword(s), rapier(s), scimitar(s), falchion(s), halberd(s), longbow, composite longbow.

Commonly-used exotic weapons: whip, bolas.

Armor

As with weapons, sidhe armor is often made from light-weight silvrion. The most common sidhe

armors are as follows: leather, chain shirt(s), scale mail(s), breast plate(s), half-plate(s), light wooden shield, heavy wooden shield.

Full plate armor is extremely rare among the sidhe, but some examples still exist in the treasury of the Underhill Court.

SIDHE NAMING CONVENTION

Since the sidhe are technically immortal and very few in number, they tend to have only one name, given to them in the days of the Tuatha de Danann. Although they are very proud of their legacy, many deliberately shorten their own names or derive nicknames from them. This is because the sidhe consider themselves to have diminished in stature since the ancient days; they no longer consider themselves worthy of their old titles.

EXAMPLE MALE NAMES

Aeda, Ailill, Arawn, Baruch, Briccriu, Caradawc, Cormac, Diancecht, Eisirt, Fachtna, Gwydion, Hevydd, Ildanach, Keltchar, Liagan, Maeldun, Natchrantal, Ogma, Pryderi, Rhonabwy, Sualtam, Talkenn, Taranus, Tiermmas.

EXAMPLE FEMALE NAMES

Aideen, Aifa, Banba, Branwen, Ceridwen, Cleena, Deirdre, Eriu, Findabair, Goewin, Kymideu, Luned, Maev, Moriath, Nessa, Olwen, Penardun, Saba, Solais, Tyren, Vivionn.



OPEN GAME LICENSE Version 1.0a

The following text is the property of Wizards of the Coast, Inc. and is Copyright 2000 Wizards of the Coast, Inc ("Wizards"). All Rights Reserved.

1. Definitions: (a) "Contributors" means the copyright and/or trademark owners who have contributed Open Game Content; (b) "Derivative Material" means copyrighted material including derivative works and translations (including into other computer languages), potation, modification, correction, addition, extension, upgrade, improvement, compilation, abridgment or other form in which an existing work may be recast, transformed or adapted; (c) "Distribute" means to reproduce, license, rent, lease, sell, broadcast, publicly display, transmit or otherwise distribute; (d) "Open Game Content" means the game mechanic and includes the methods, procedures, processes and routines to the extent such content does not embody the Product Identity and is an enhancement over the prior art and any additional content clearly identified as Open Game Content by the Contributor; and means any work covered by this License, including translations and derivative works under copyright law, but specifically excludes Product Identity. (e) "Product Identity" means product and product line names, logos and identifying marks including trade dress; artifacts; creatures characters; stories, storylines, plots, thematic elements, dialogue, incidents, language, artwork, symbols, designs, depictions, likenesses, formats, poses, concepts, themes and graphic, photographic and other visual or audio representations; names and descriptions of characters, spells, enchantments, personalities, teams, personas, likenesses and special abilities; places, locations, environments, creatures, equipment, magical or supernatural abilities or effects, logos, symbols, or graphic designs; and any other trademark or registered trademark clearly identified as Product identity by the owner of the Product Identity, and which specifically excludes the Open Game Content; (f) "Trademark" means the logos, names, mark, sign, motto, designs that are used by a Contributor to identify itself or its products or the associated products contributed to the Open Game License by the Contributor (g) "Use", "Used" or "Using" means to use, Distribute, copy, edit, format, modify, translate and otherwise create Derivative Material of Open Game Content. (h) "You" or "Your" means the licensee in terms of this agreement.

2. The License: This License applies to any Open Game Content that contains a notice indicating that the Open Game Content may only be Used under and in terms of this License. You must affix such a notice to any Open Game Content that you Use. No terms may be added to or subtracted from this License except as described by the License

itself. No other terms or conditions may be applied to any Open Game Content distributed using this License.

3. Offer and Acceptance: By Using the Open Game Content You indicate Your acceptance of the terms of this License.

4. Grant and Consideration: In consideration for agreeing to use this License, the Contributors grant You a perpetual, worldwide, royalty-free, non-exclusive license with the exact terms of this License to Use, the Open Game Content.

5. Representation of Authority to Contribute: If You are contributing original material as Open Game Content, You represent that Your Contributions are Your original creation and/or You have sufficient rights to grant the rights conveyed by this License.

6. Notice of License Copyright: You must update the COPYRIGHT NOTICE portion of this License to include the exact text of the COPYRIGHT NOTICE of any Open Game Content You are copying, modifying or distributing, and You must add the title, the copyright date, and the copyright holder's name to the COPYRIGHT NOTICE of any original Open Game Content you Distribute.

7. Use of Product Identity: You agree not to Use any Product Identity, including as an indication as to compatibility, except as expressly licensed in another, independent Agreement with the owner of each element of that Product Identity. You agree not to indicate compatibility or co-adaptability with any Trademark or Registered Trademark in conjunction with a work containing Open Game Content except as expressly licensed in another, independent Agreement with the owner of such Trademark or Registered Trademark. The use of any Product Identity in Open Game Content does not constitute a challenge to the ownership of that Product Identity. The owner of any Product Identity used in Open Game Content shall retain all rights, title and interest in and to that Product Identity.

8. Identification: If you distribute Open Game Content You must clearly indicate which portions of the work that you are distributing are Open Game Content.

9. Updating the License: Wizards or its designated Agents may publish updated versions of this License. You may use any authorized version of this License to copy, modify and distribute any Open Game Content originally distributed under any version of this License.

10. Copy of this License: You MUST include a copy of this License with every copy of the Open Game Content You Distribute.

11. Use of Contributor Credits: You may not market or advertise the Open Game

Content using the name of any Contributor unless You have written permission from the Contributor to do so.

12. Inability to Comply: If it is impossible for You to comply with any of the terms of this License with respect to some or all of the Open Game Content due to statute, judicial order, or governmental regulation then You may not Use any Open Game Material so affected.

13. Termination: This License will terminate automatically if You fail to comply with all terms herein and fail to cure such breach within 30 days of becoming aware of the breach. All sublicenses shall survive the termination of this License.

14. Reformation: If any provision of this License is held to be unenforceable, such provision shall be reformed only to the extent necessary to make it enforceable.

15. COPYRIGHT NOTICE
Open Game License v 1.0 Copyright 2000, Wizards of the Coast, Inc.

System Reference Document Copyright 2000-2003, Wizards of the Coast, Inc.; Authors Jonathan Tweet, Monte Cook, Skip Williams, Rich Baker, Andy Collins, David Noonan, Rich Redman, Bruce R. Cordell, John D. Rateliff, Thomas Reid, James Wyatt, based on original material by E. Gary Gygax and Dave Arneson.

Folkloric: The Underhill Court © 2005 Dog Soul Publishing; Deborah Balsam and Sean C. Frolich

clipart images © 2005 JupiterImages Corporation

original artwork © 2005 Cris Griffin and Jimmy Ling

Open Game Content:
All materials and content, barring original artwork, place names, proper names, and adventure descriptions and original fiction is provided as Open Content.

DESIGNATION OF PRODUCT IDENTITY
The following items are designated as Product Identity in accordance with section 1 (e) of the Open Gaming license version 1.0. All content not specifically listed as OGC or clipart, including all art and narratives, Dog Soul Publishing, and any logos belonging to the former.

Book of Maps



DOG SOUL
publishing

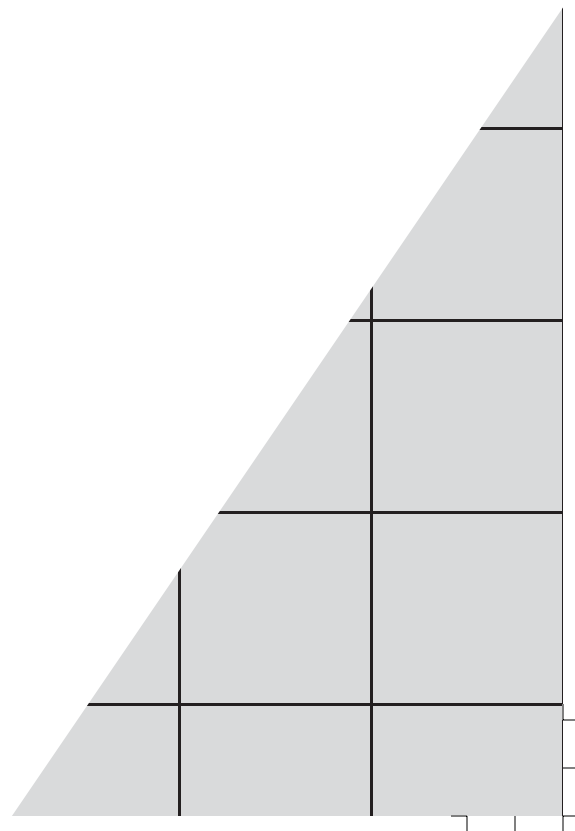

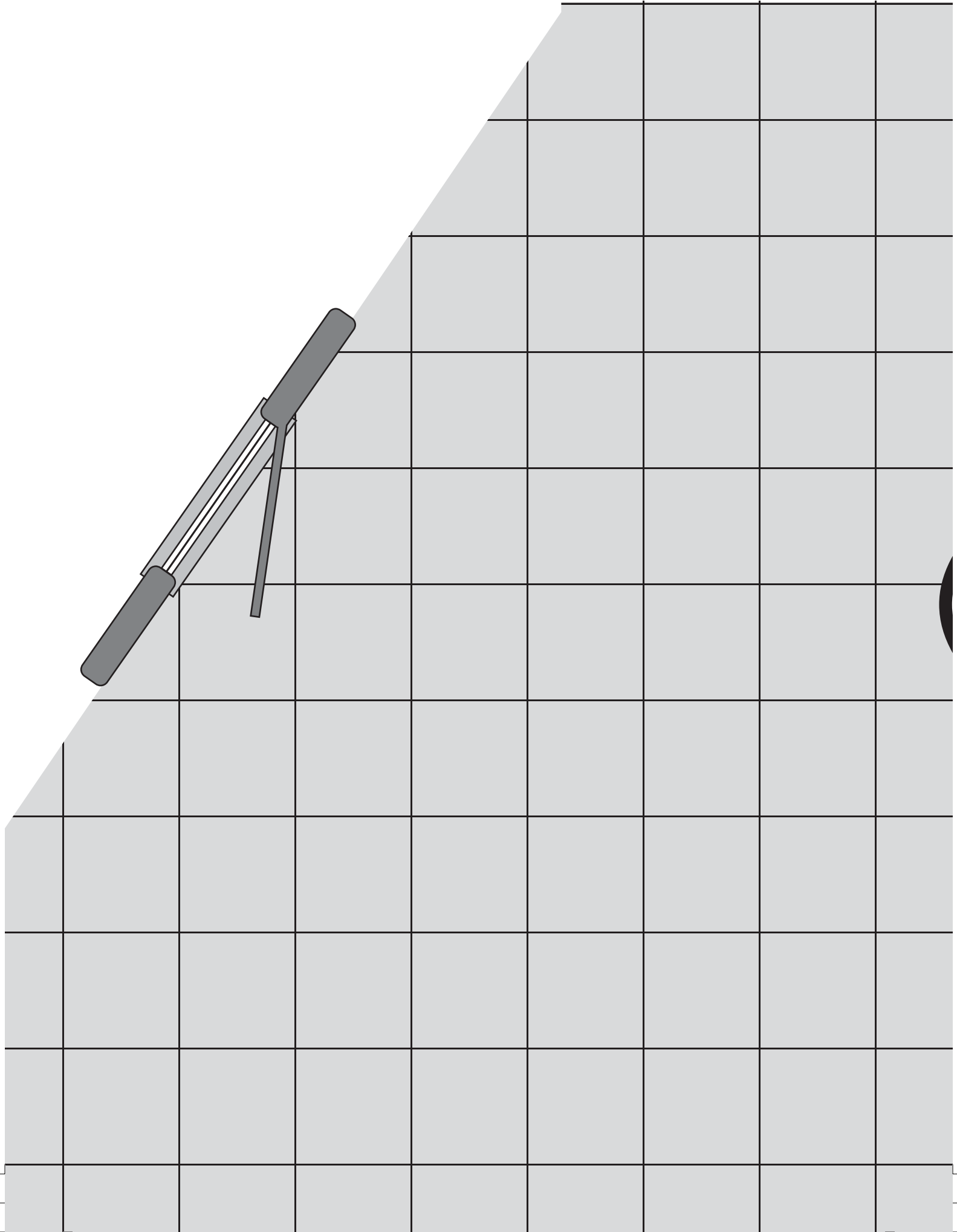

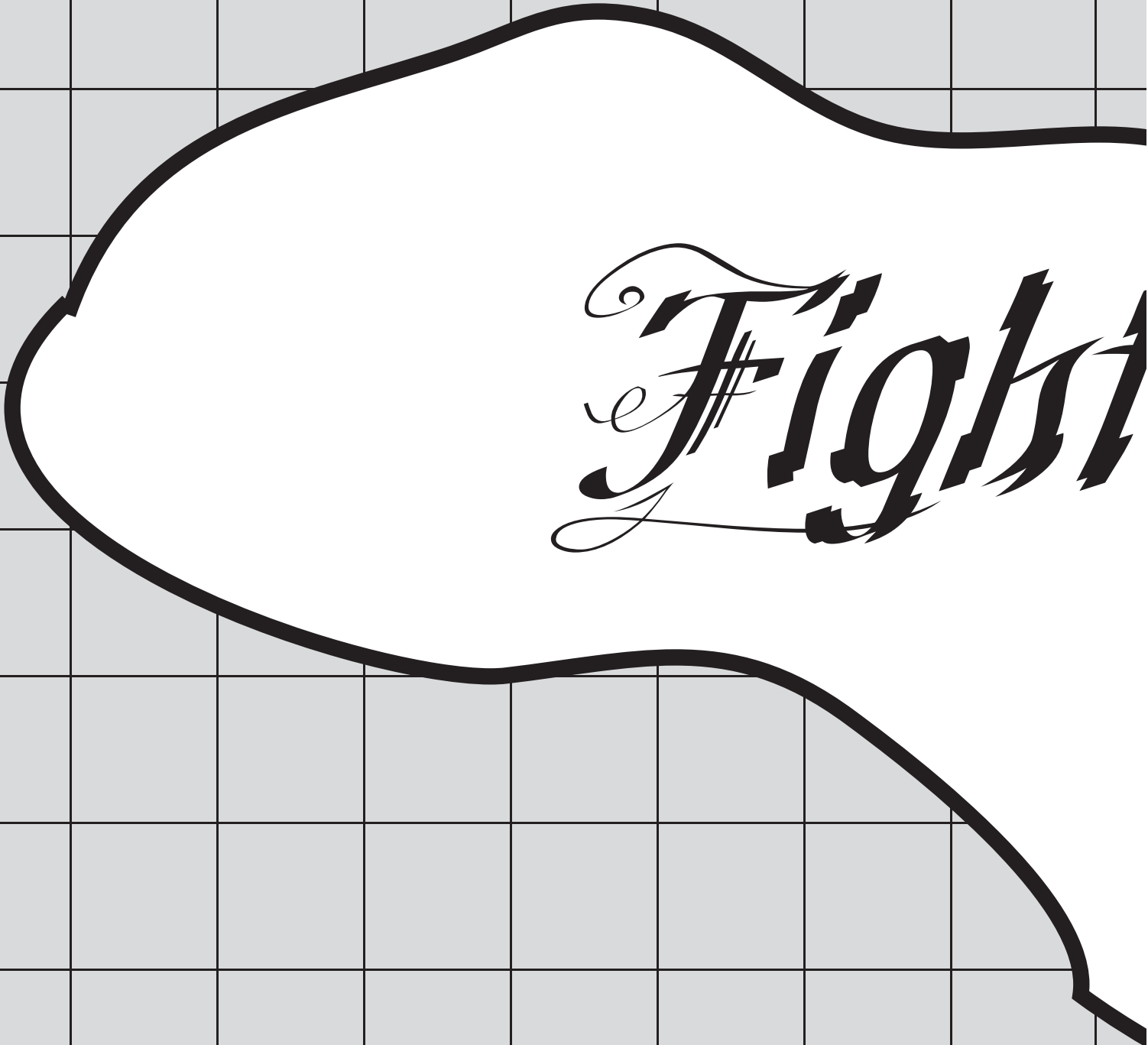
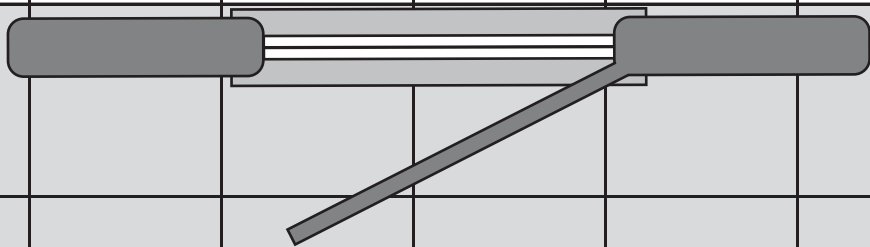

Fight



King Pit



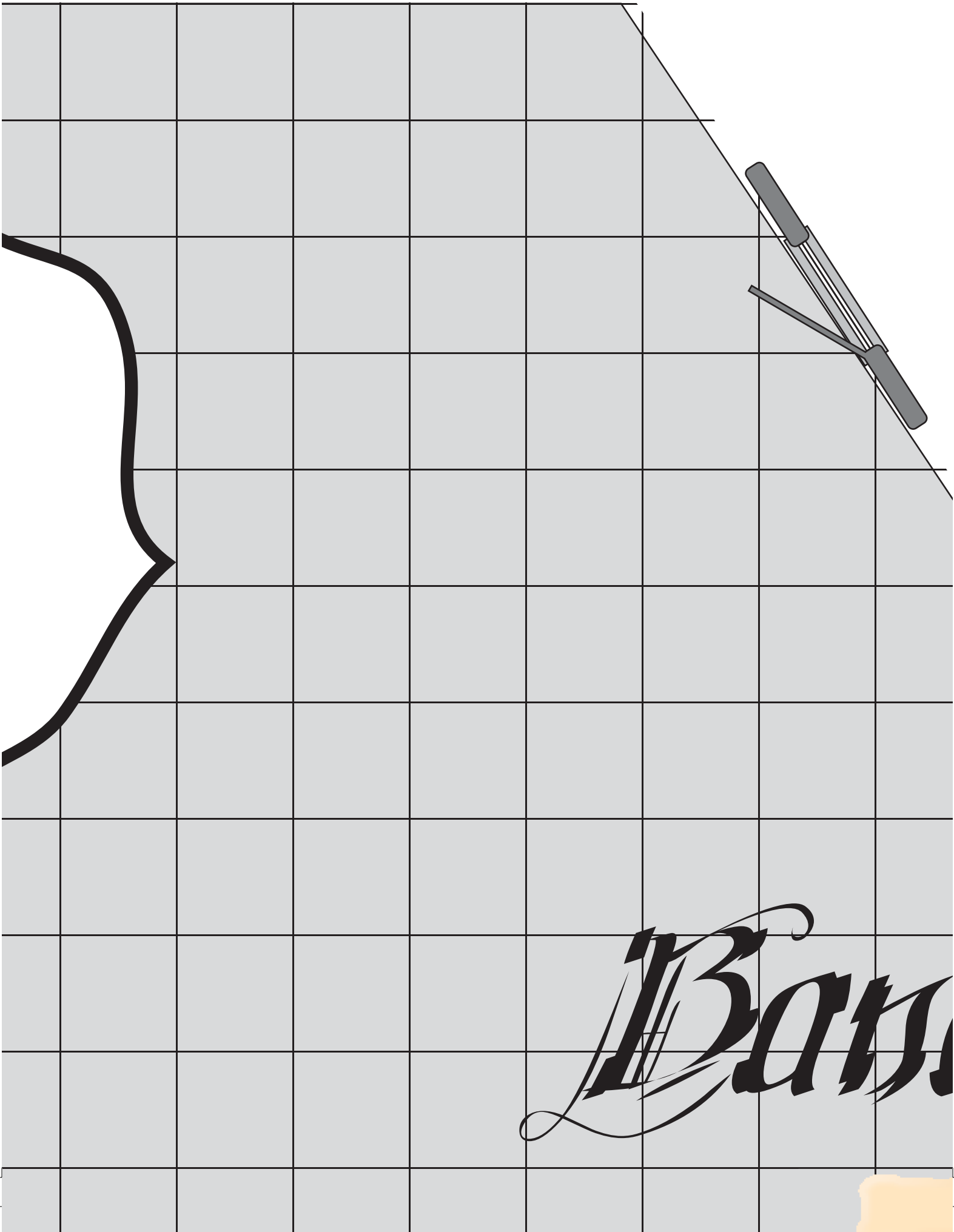

Bans



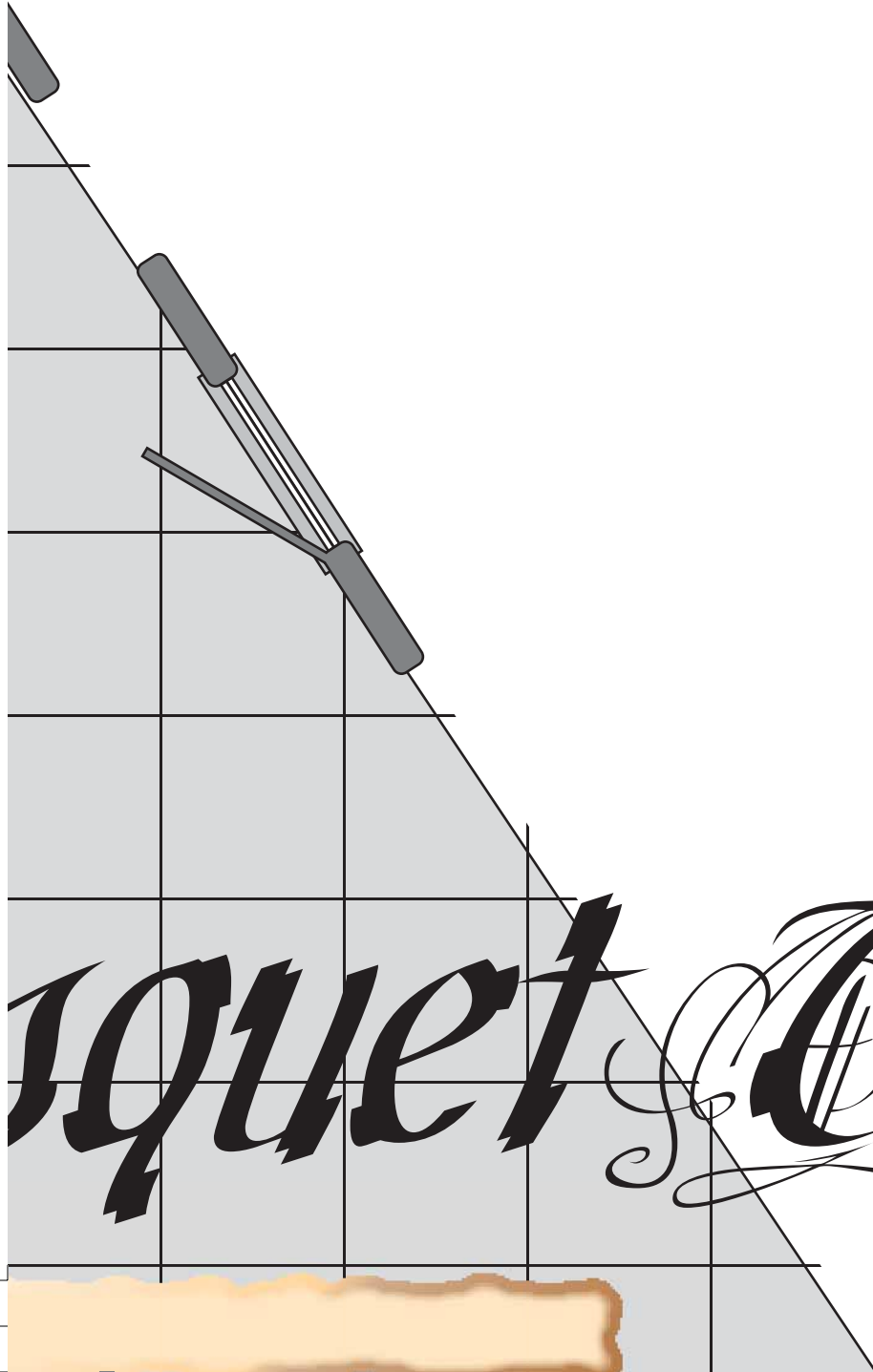

quiet Tables



5

Thrones / Dais

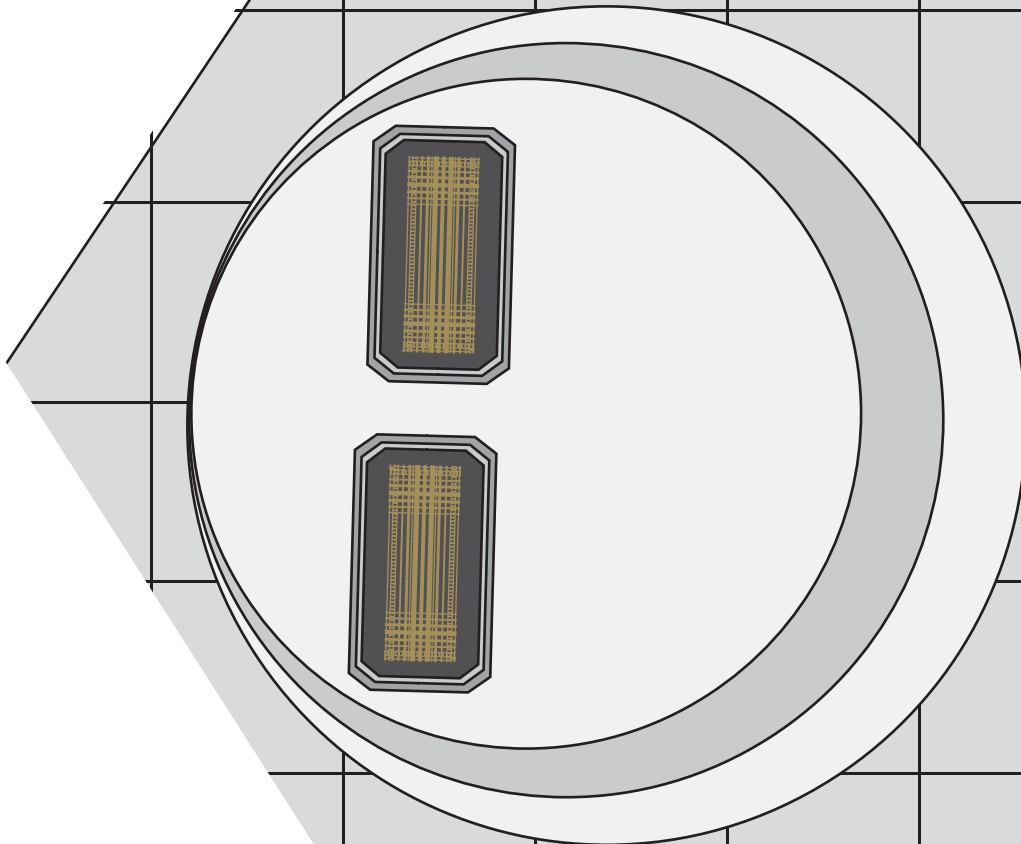

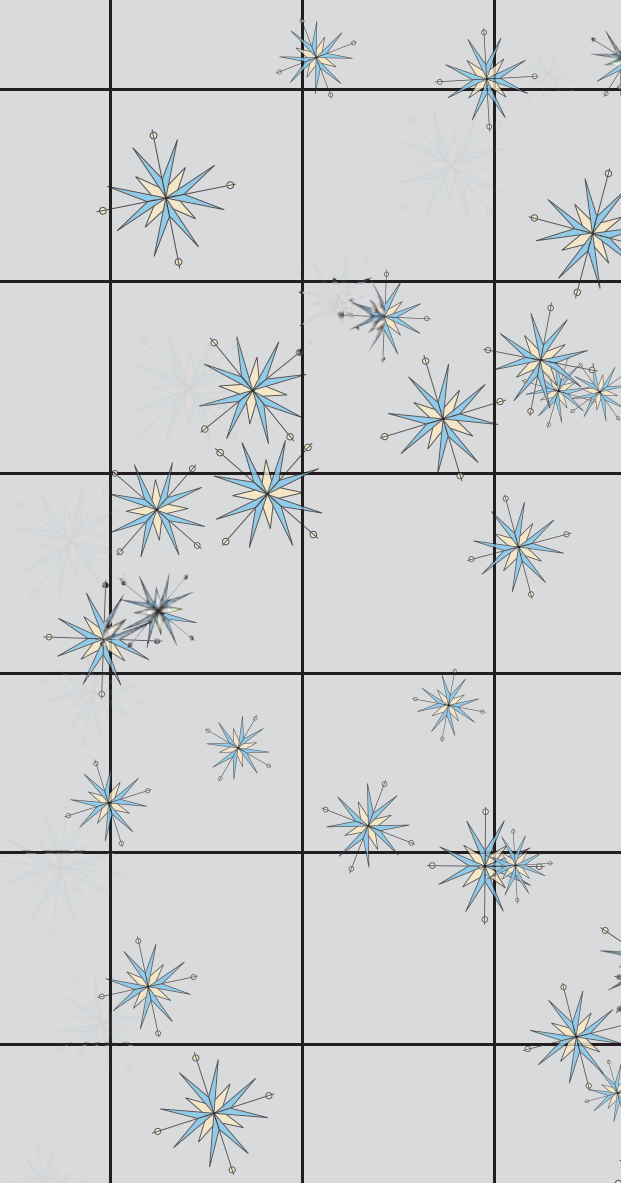
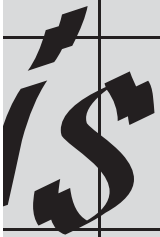

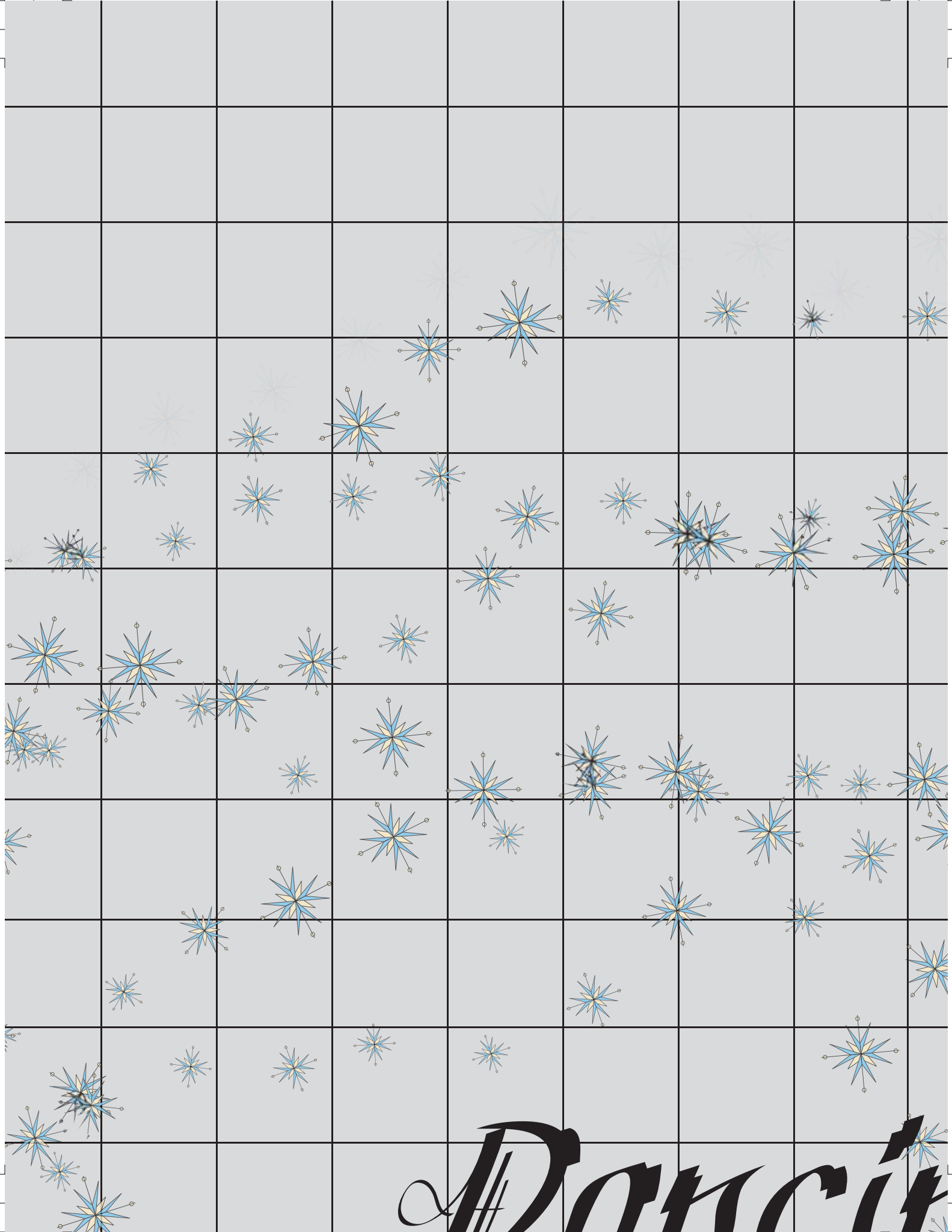

Dance it

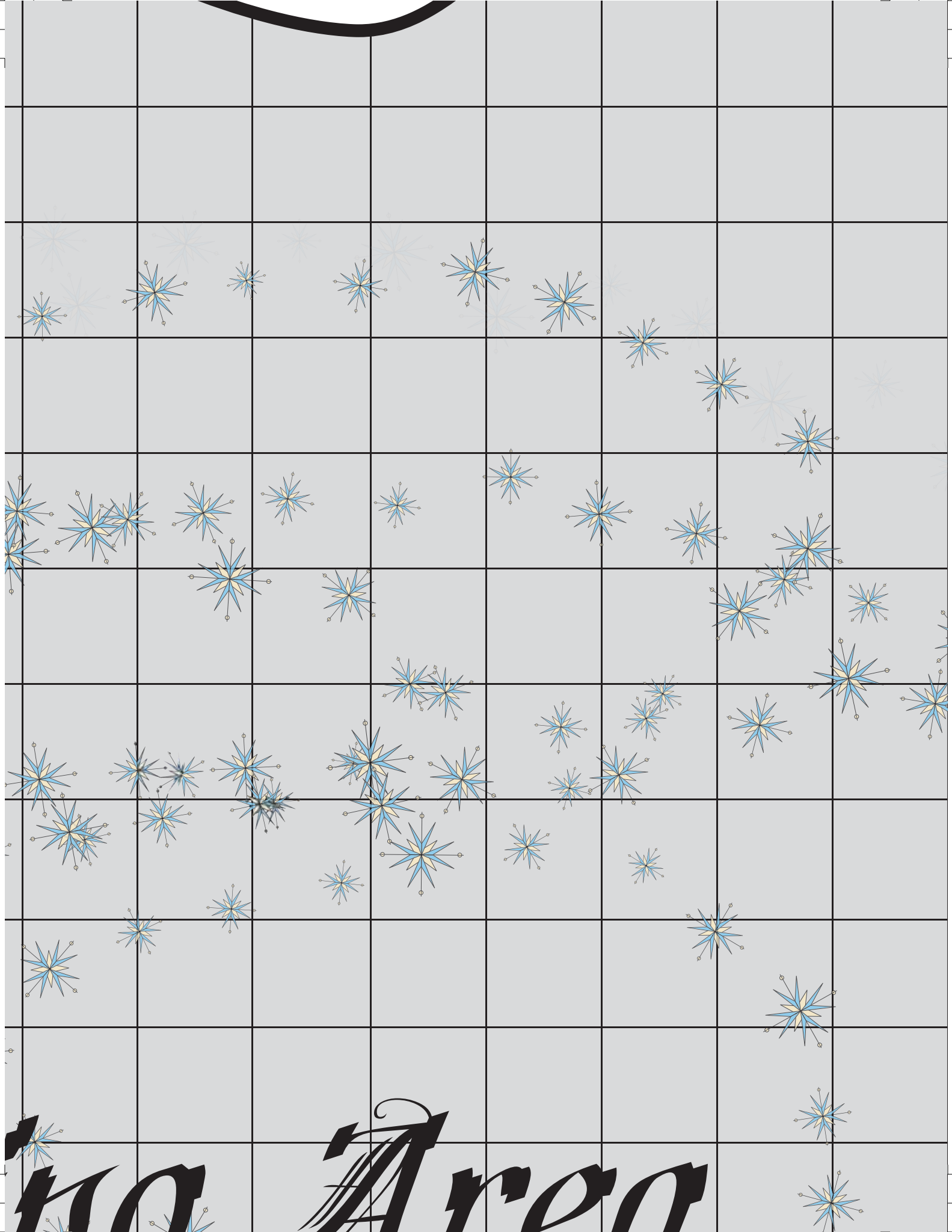

na Area

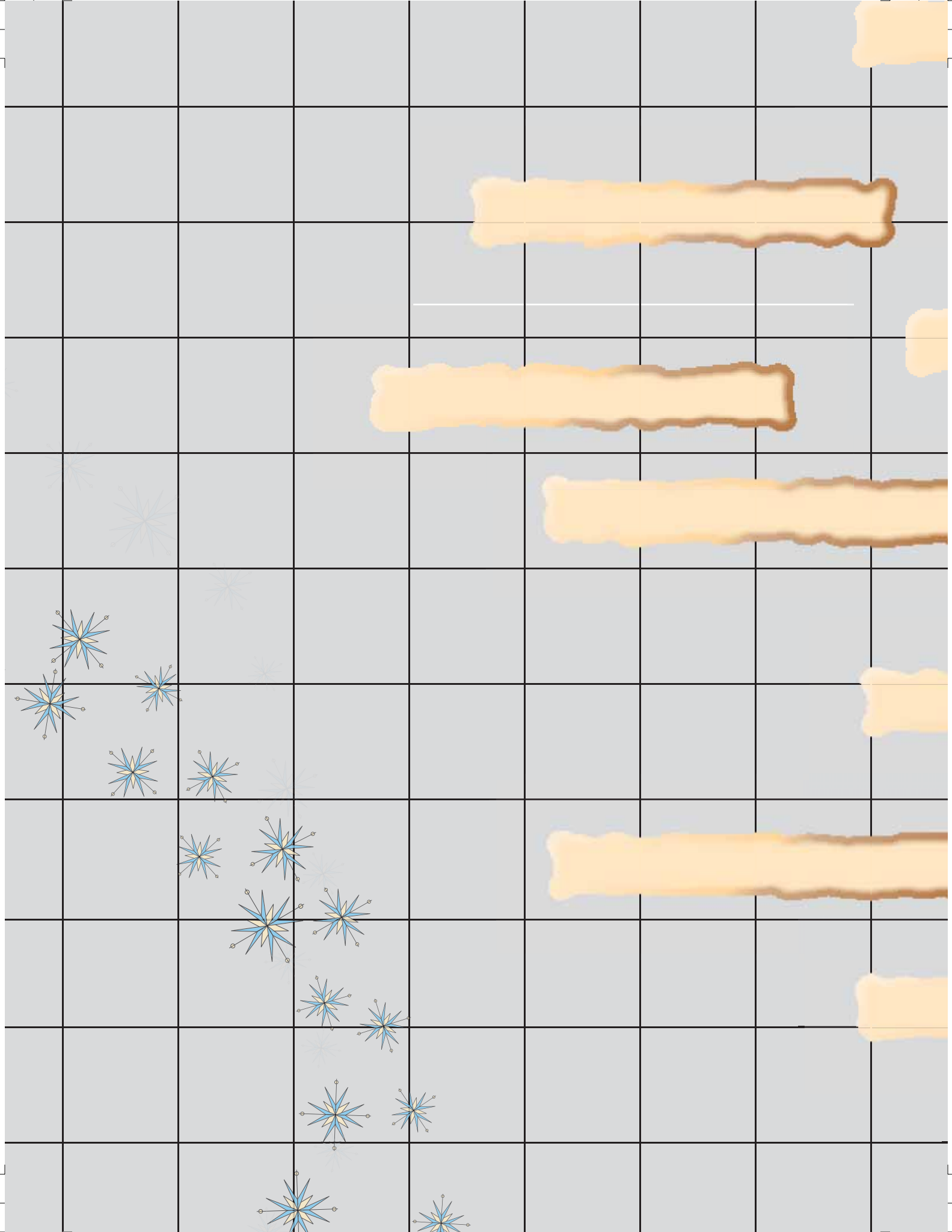

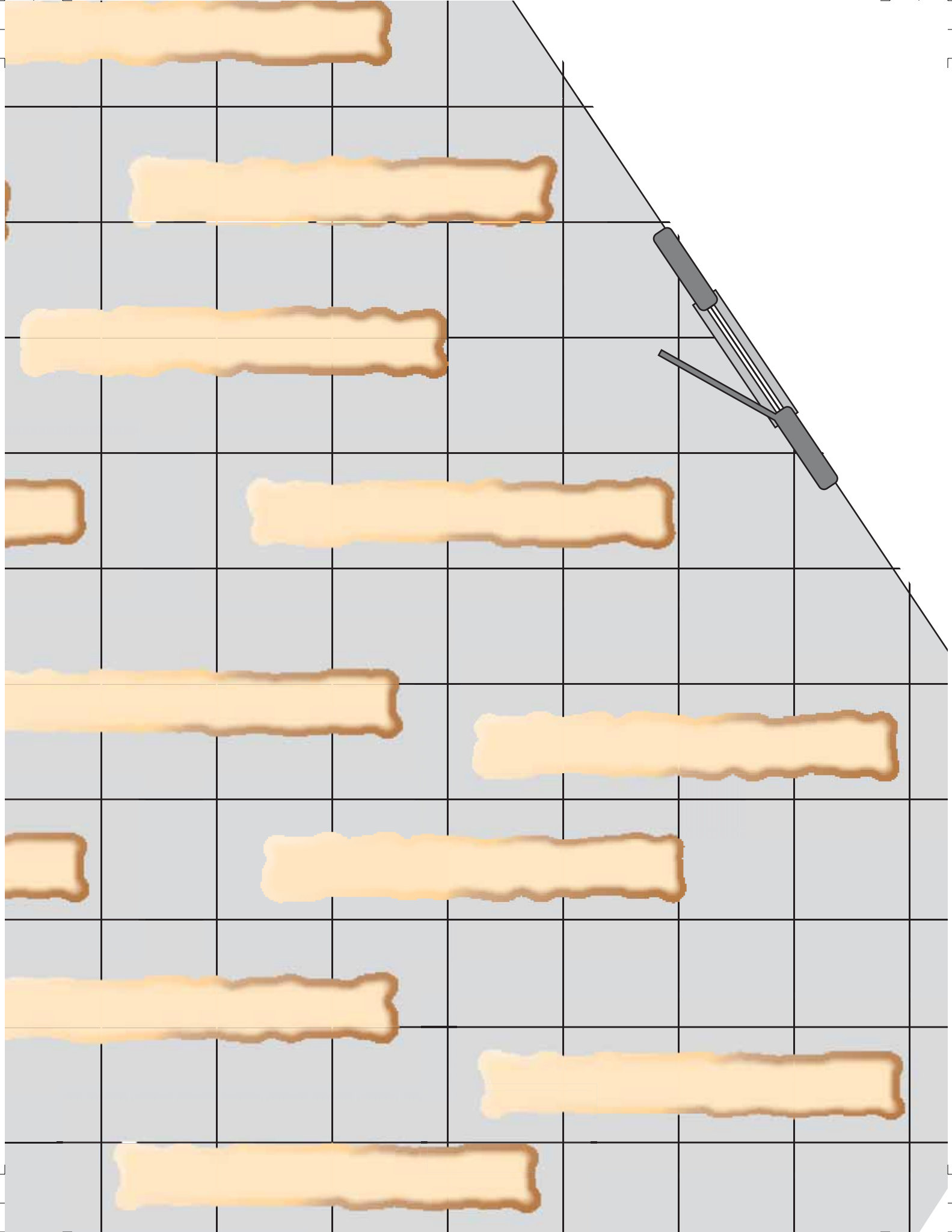

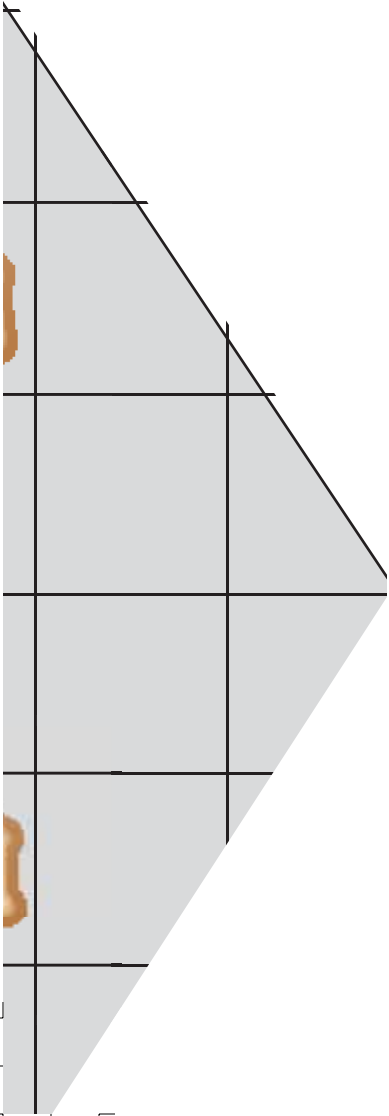

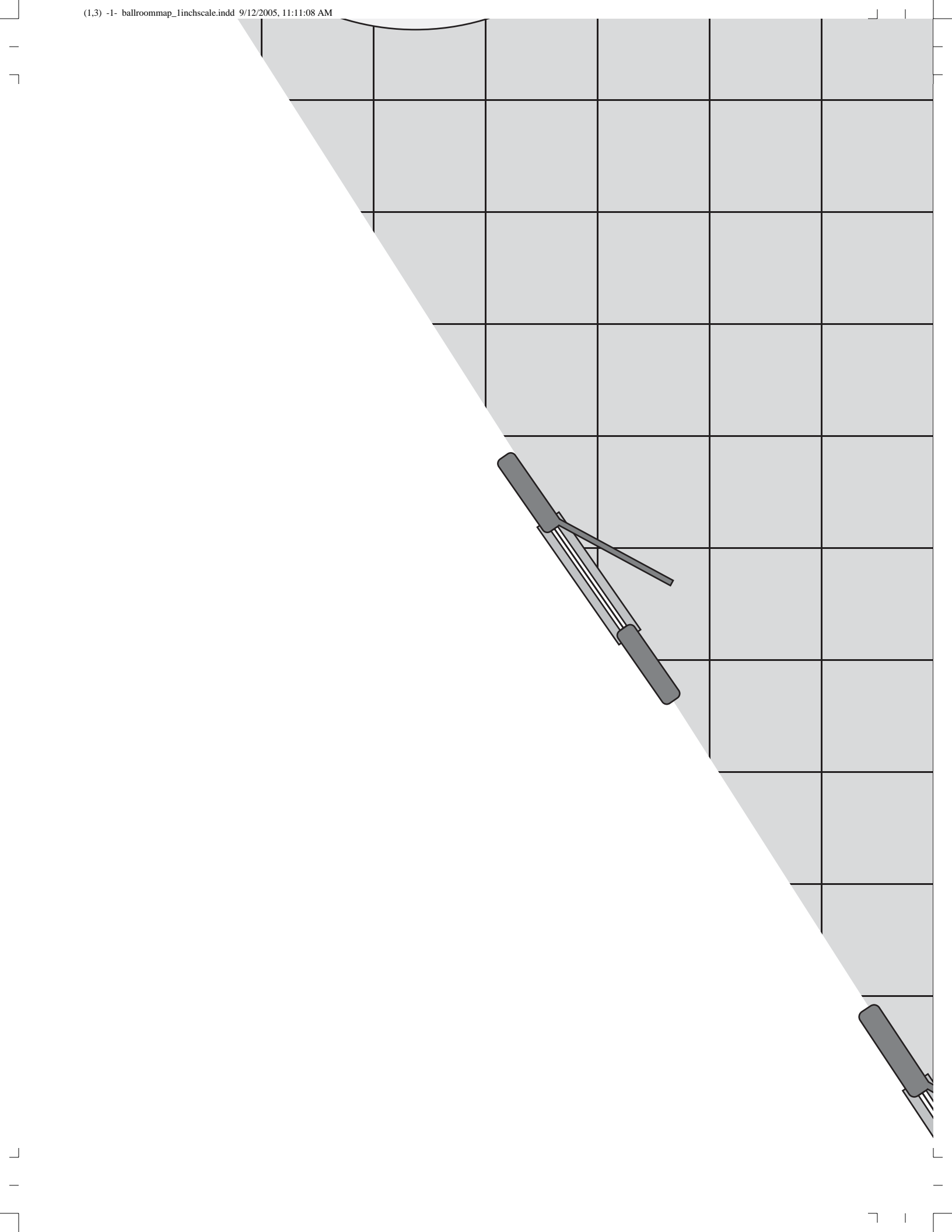

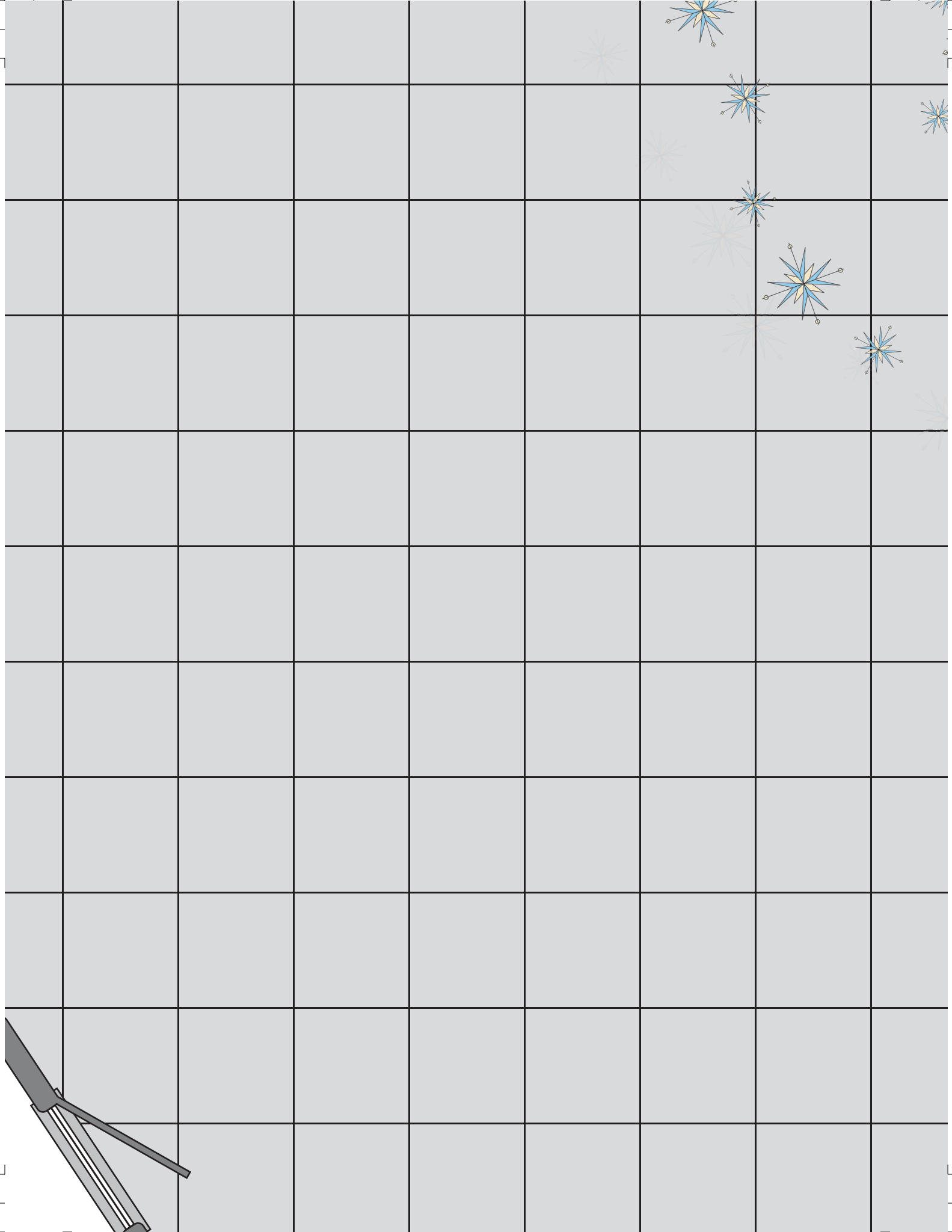

Waltz

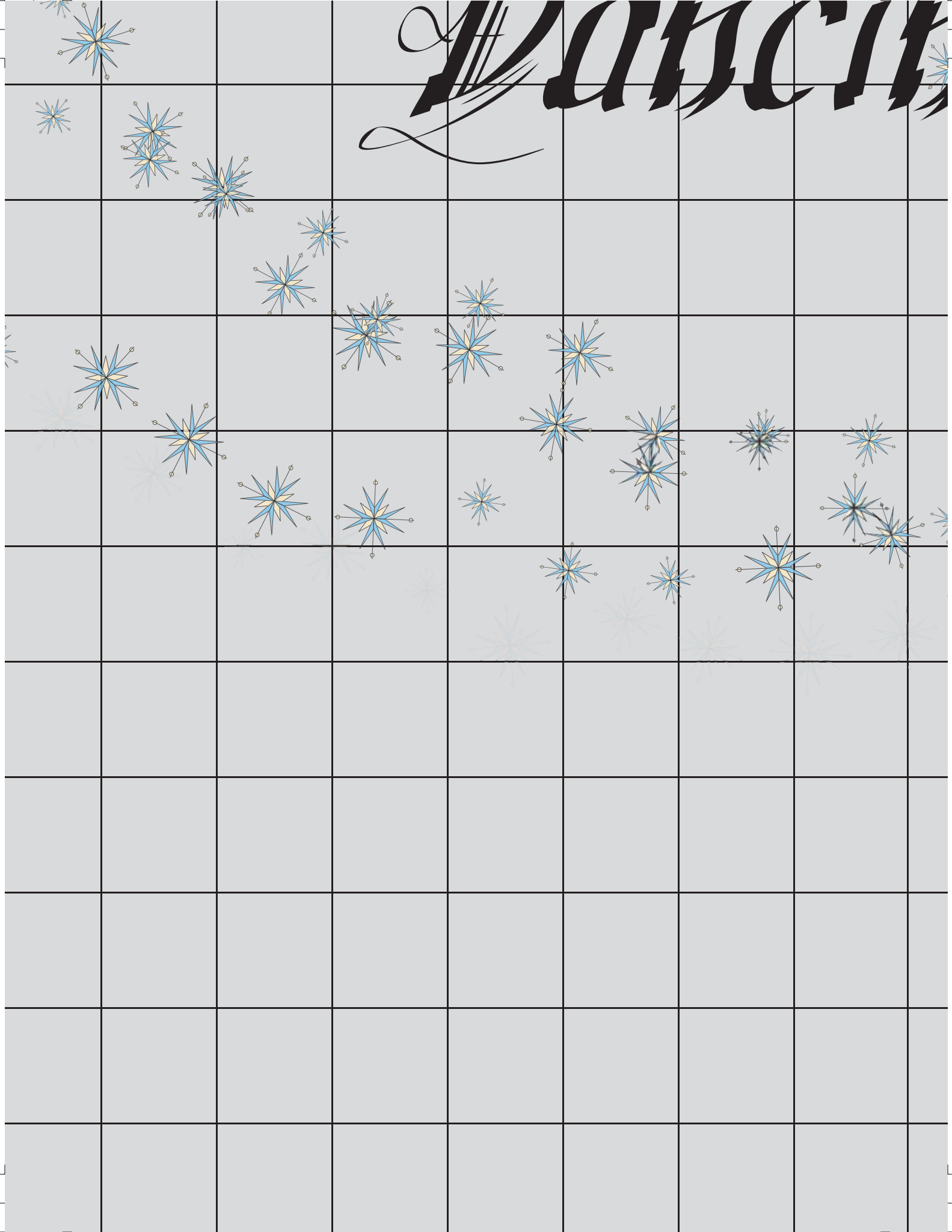

Big Area

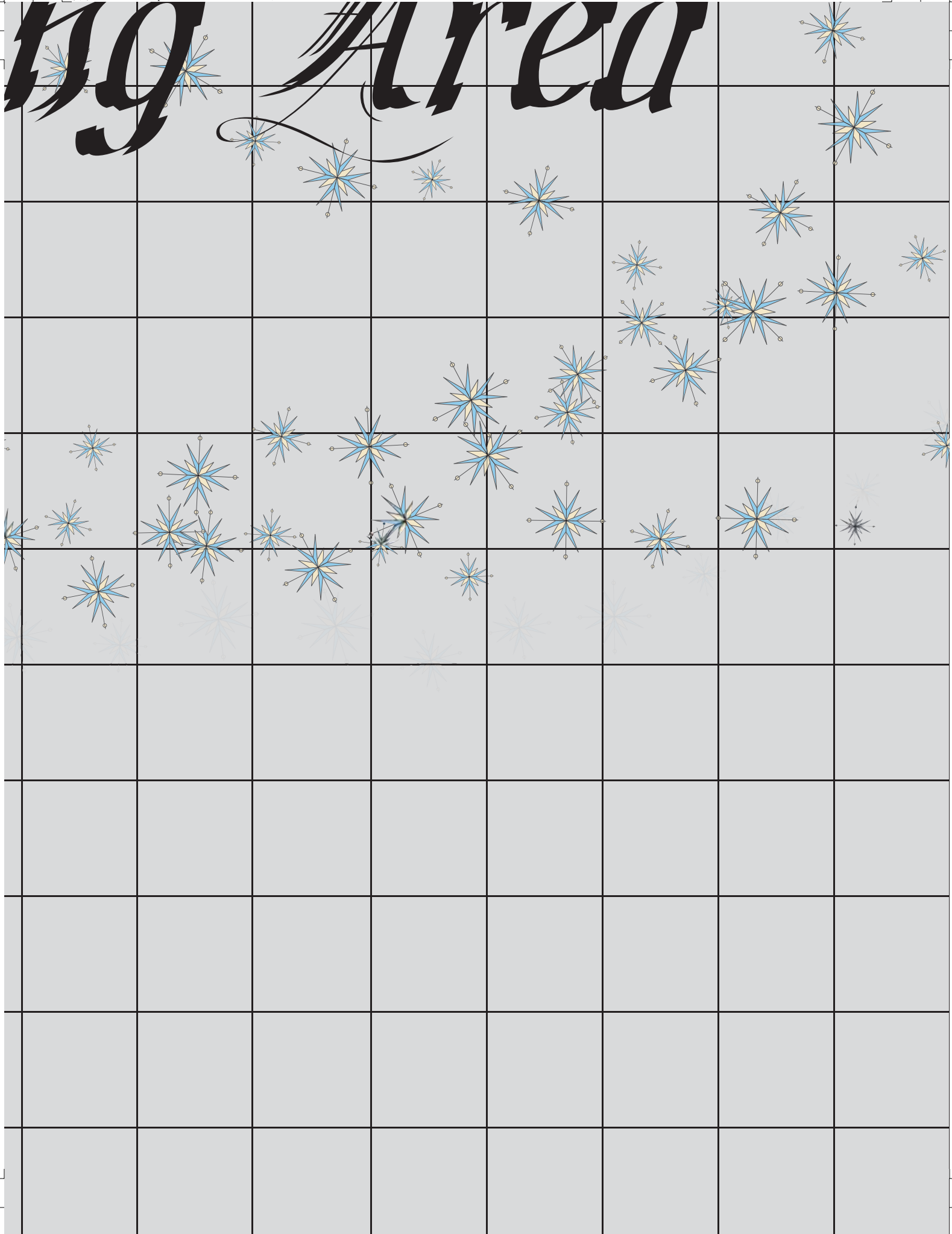

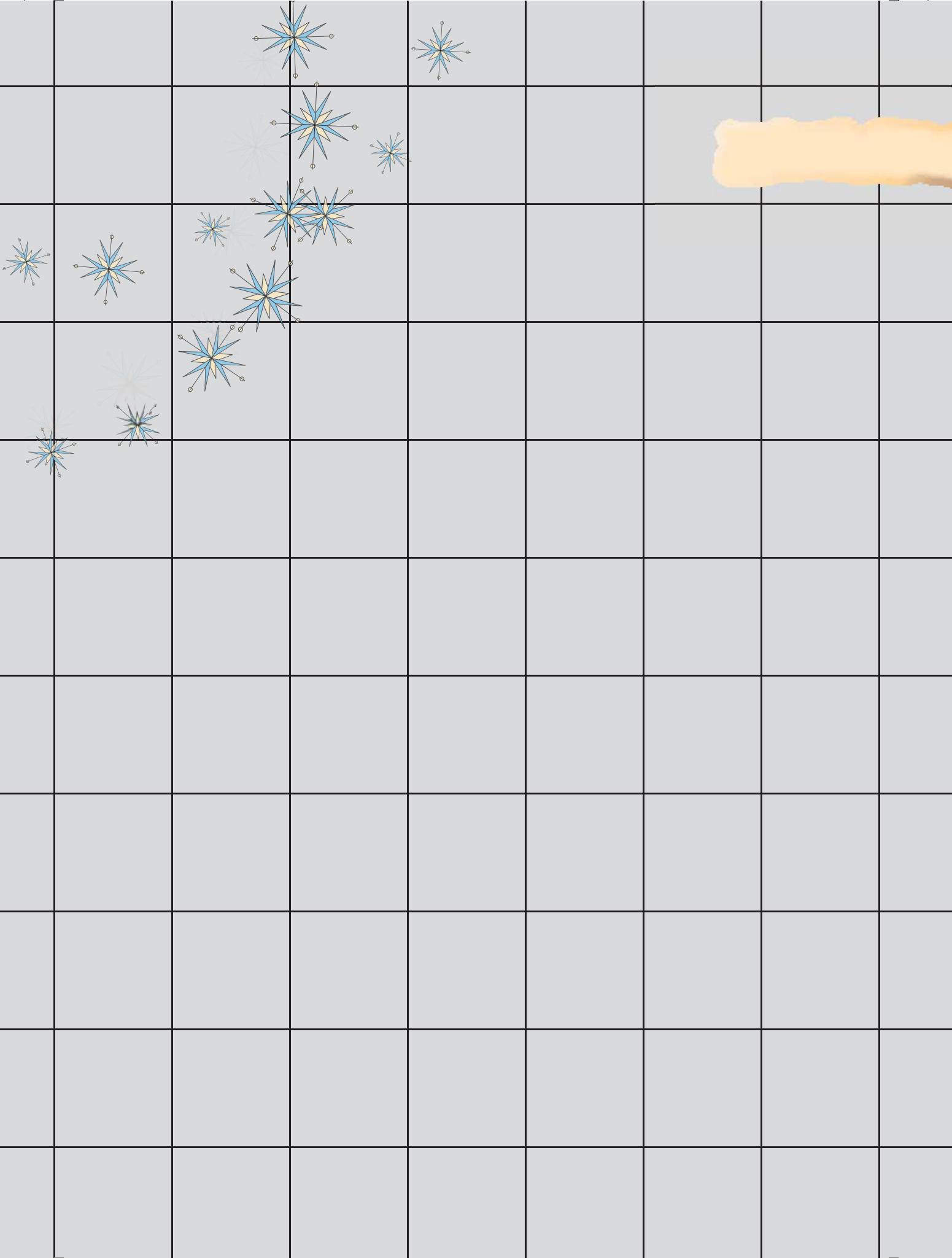

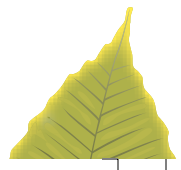
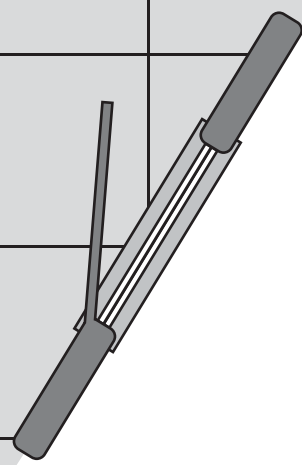
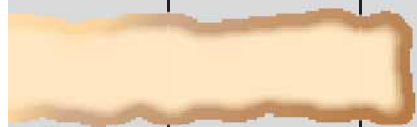



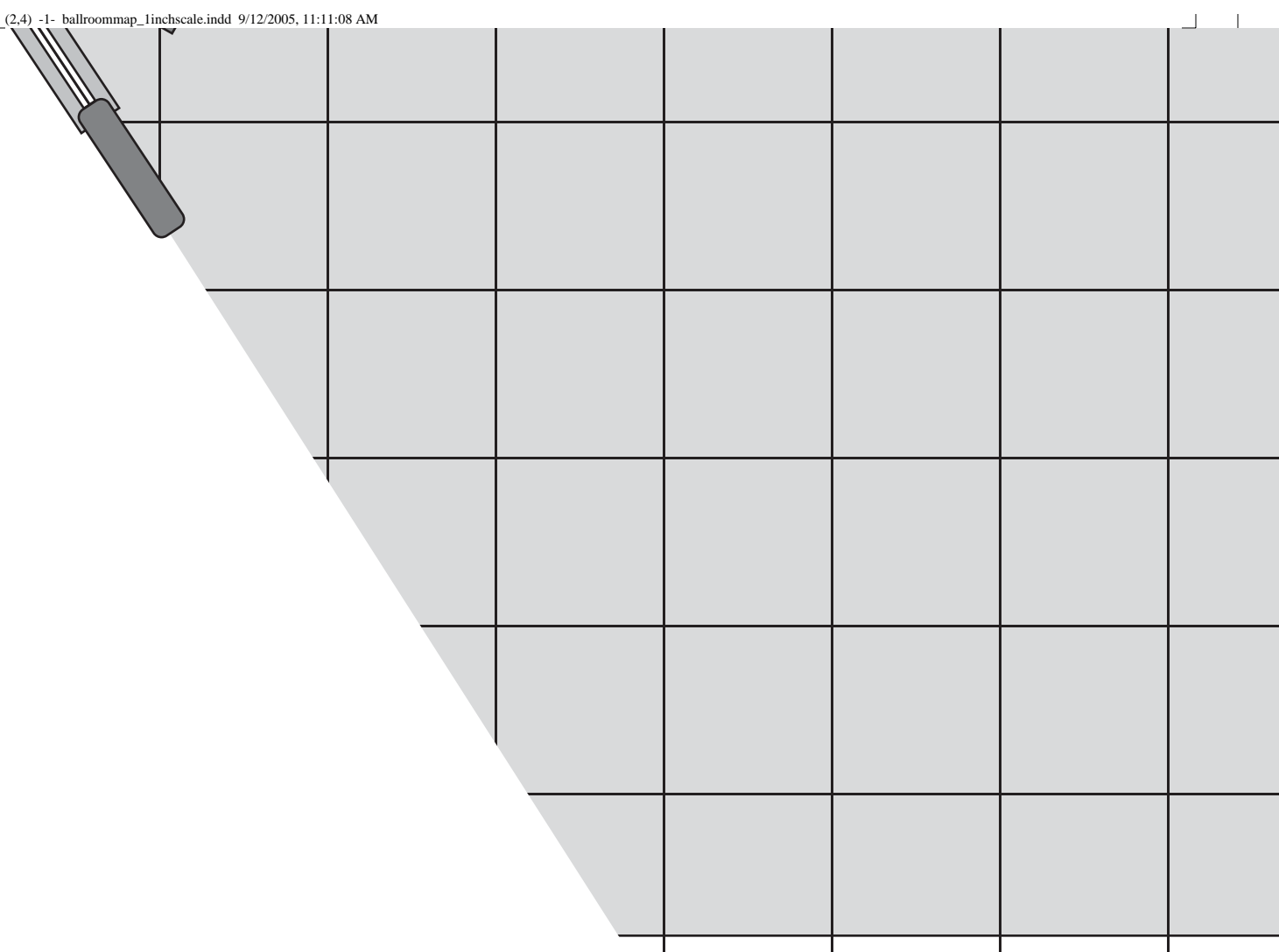

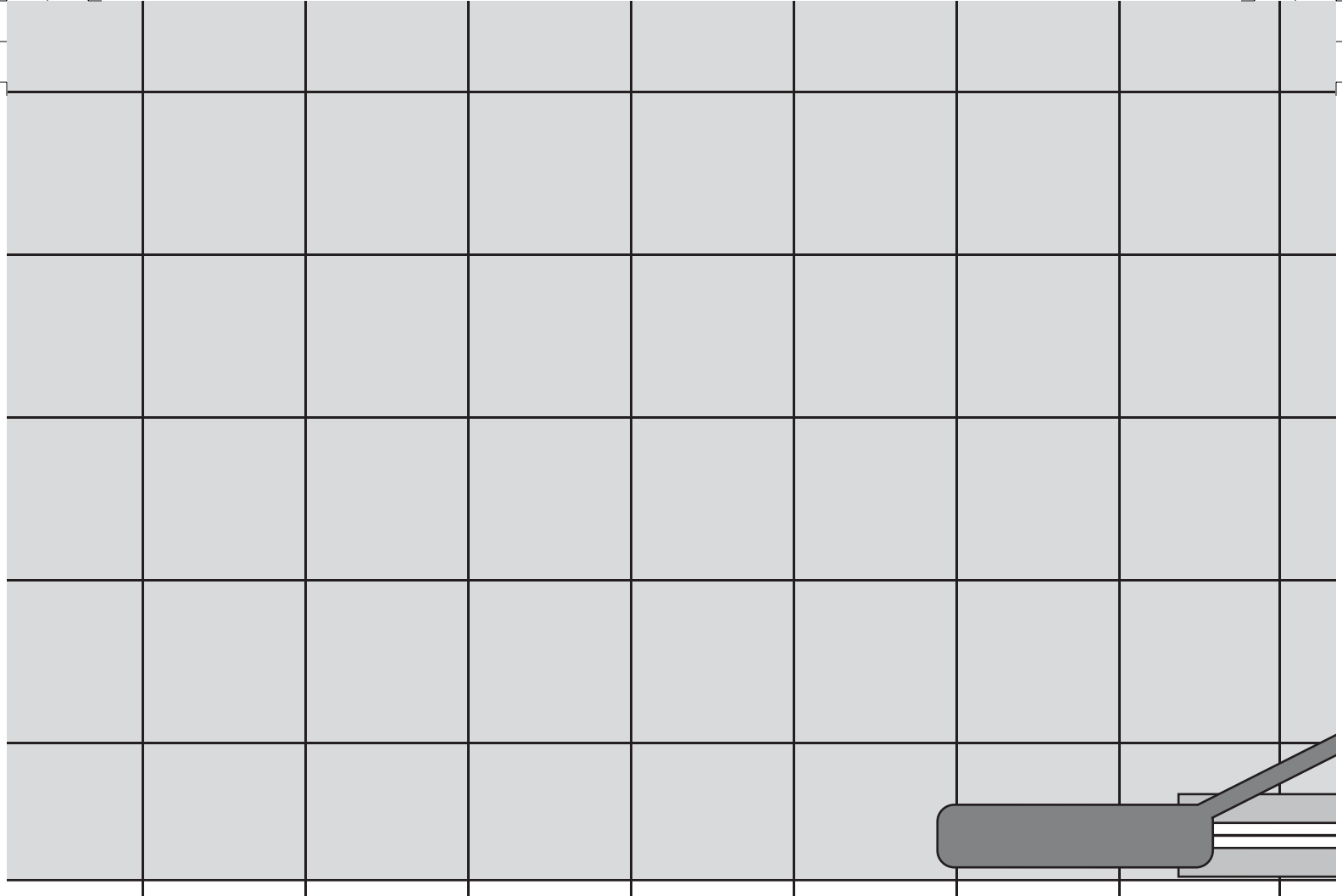

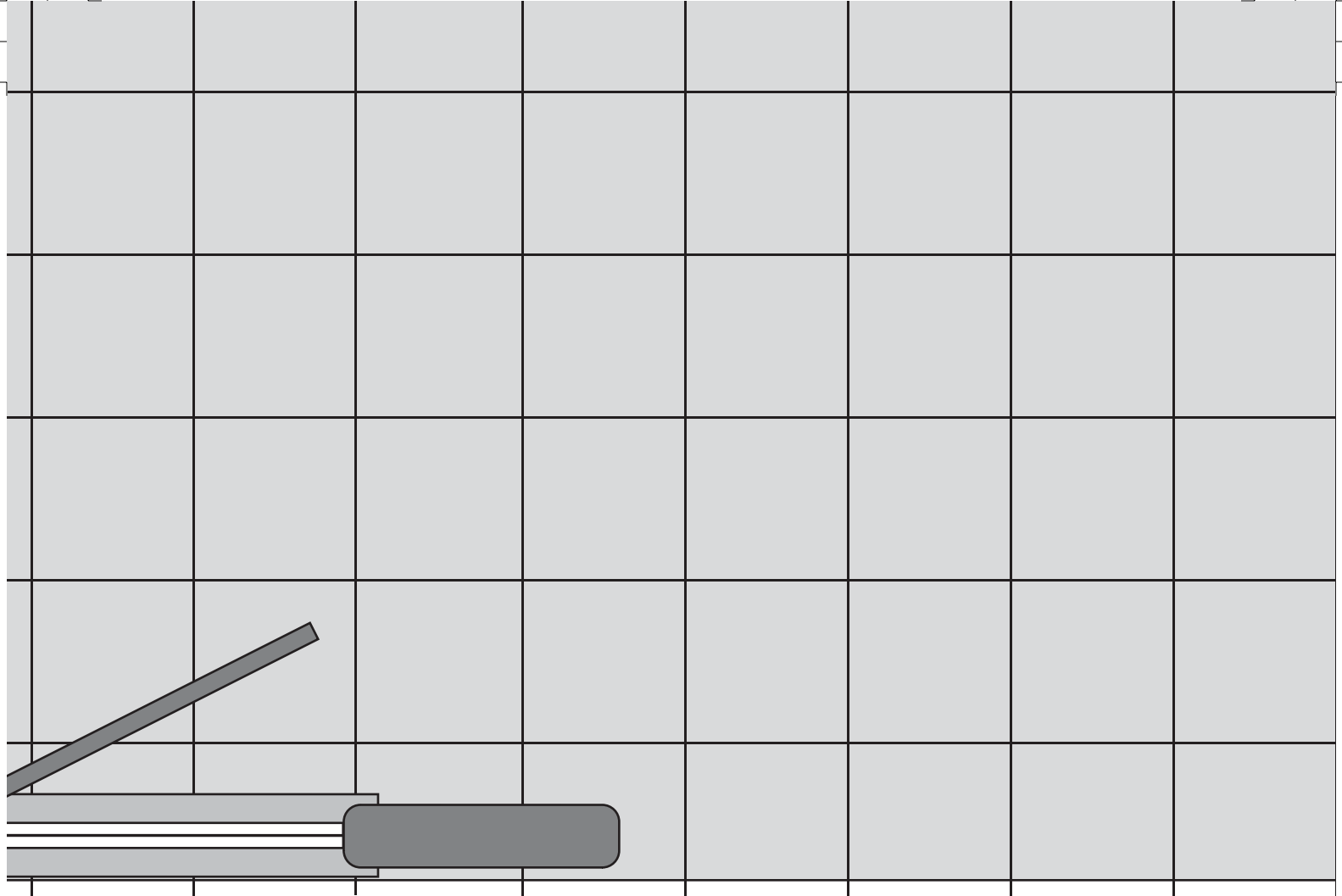

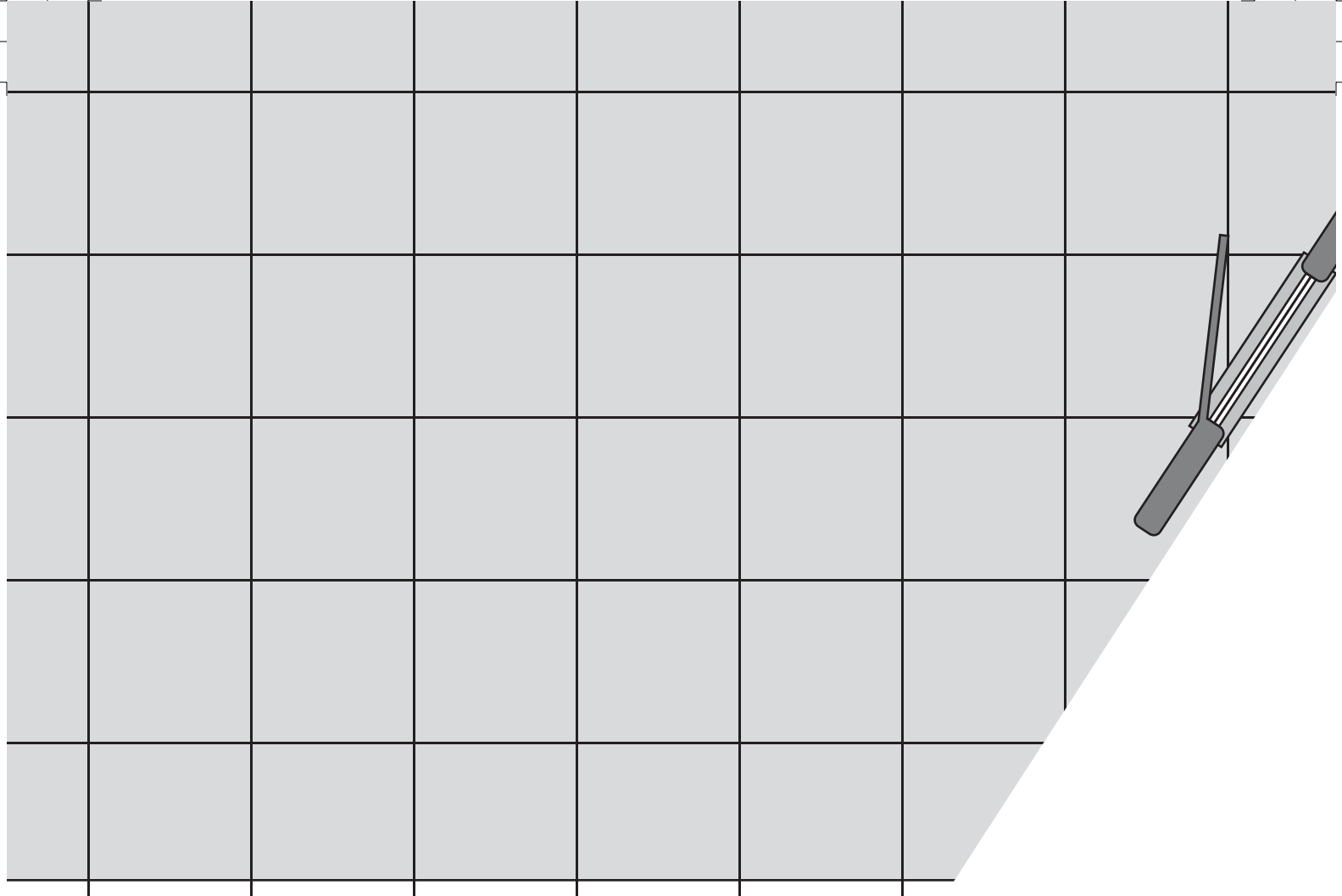

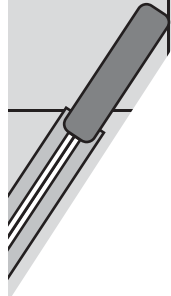

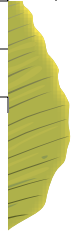

-

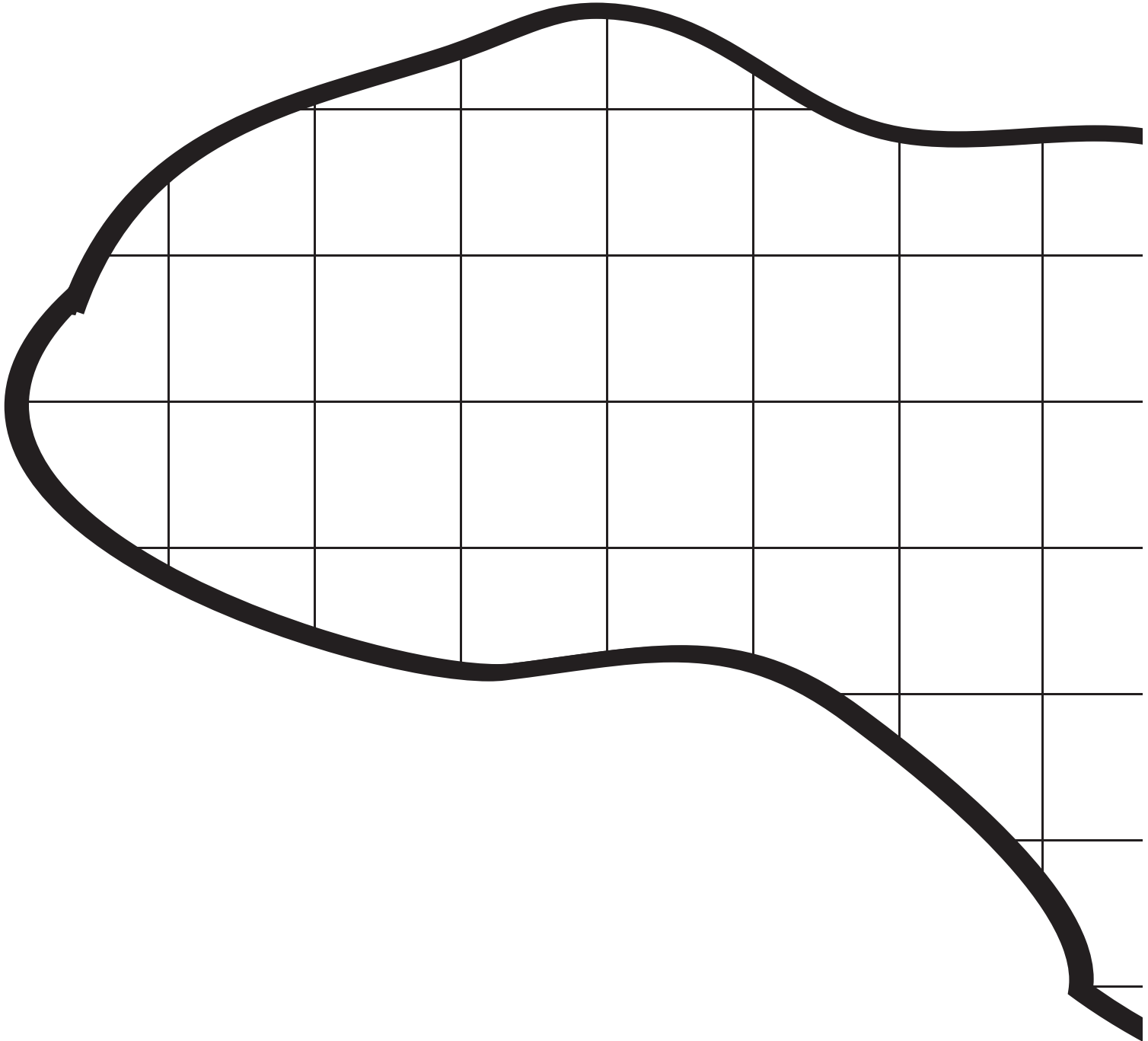

Fighting Pit

Gate

